

# **TRAK<sup>®</sup> TC2 Turning Center ProtoTRAK<sup>®</sup> RLX CNC**

---

**Safety, Installation, Maintenance, Service & Parts List**

Document:	P/N 35006
Version:	101724

**TRAK** MACHINE  
TOOLS



**SOUTHWESTERN INDUSTRIES, INC.**

2615 Homestead Place

Rancho Dominguez, CA 90220-5610 USA

T | 310.608.4422 | F | 310.764.2668

Service Department: 800.367.3165

E-mail: [sales@trakmt.com](mailto:sales@trakmt.com) | [service@trakmt.com](mailto:service@trakmt.com) | web: [www.trakmt.com](http://www.trakmt.com)

Copyright © 2024, Southwestern Industries, Inc. All rights are reserved. No part of this publication may be reproduced, stored in a retrieval system, or transmitted, in any form or by any means, mechanical, photocopying, recording or otherwise, without the prior written permission of Southwestern Industries, Inc.

While every effort has been made to include all the information required for the purposes of this guide, Southwestern Industries, Inc. assumes no responsibility for inaccuracies or omission and accepts no liability for damages resulting from the use of the information contained in this guide.

All brand names and products are trademarks or registered trademarks of their respective holders.

**TRAK Machine Tools**

**Southwestern Industries, Inc.**

2615 Homestead Place

Rancho Dominguez, CA 90208-5610

Phn 310.608.4422 ◆ Fax 310.764.2668

Service Department

Phn 800.367.3165 ◆ Fax 310.886.8029

# Table of Contents

<b>1.0</b>	<b>Safety Requirements .....</b>	<b>2</b>
1.1	Safety Publications .....	2
1.2	Danger, Warning, Caution, and Note Labels and Notices as Used In This Manual .....	2
1.3	Safety Precautions.....	7
<b>2.0</b>	<b>Installation .....</b>	<b>9</b>
2.1	Floor Plan, Layout & Space Requirements .....	9
2.2	Uncrating.....	11
2.3	Lifting and/or Moving the Machine.....	11
2.4	Shortages: Inventory Checklist.....	15
2.5	Installation Instructions & Checklist.....	16
2.6	ProtoTRAK RLX Control Hardware.....	17
2.7	Cleaning .....	18
2.8	Leveling.....	18
2.8.1	Leveling .....	19
2.9	Electrical Connection .....	20
2.10	Phase Converters .....	21
2.11	Air Connection .....	21
2.12	Machine ID Key.....	21
2.13	Pendant Maintenance .....	22
2.13.1	How to Clean the Touchscreen .....	22
2.14	Lubrication.....	22
2.14.1	Lube Pump Operation.....	22
2.14.2	Factory Default Values .....	22
2.15	Auxiliary Output .....	22
2.16	Cutting the Test Part .....	25
2.17	Measurement of the Test Part.....	25
2.18	Mounting of a Buck (or TRAK/Accutek) Zero Set Chuck- RX Lathe .....	25
2.19	Machines with Hydraulic Chuck option installed.....	27
2.20	Cabinet Heat Exchanger .....	28
<b>3.0</b>	<b>Troubleshooting by Symptom.....</b>	<b>29</b>
3.1	Problems Related to the Pendant and Computer Module.....	29
3.1.1	Pendant will not Connect to Motion Control in Computer Module at Boot Up.....	29
3.1.2	Pendant will not Connect to Motion Control in Computer Module .....	29
3.1.3	Pendant Does Not Power On .....	30
3.1.4	Screen Problems.....	30
3.1.5	RSG Button Does Not Work .....	30
3.1.6	System Does Not Respond to Numeric Keys Button Presses .....	31
3.1.7	System Does Not Respond to Critical Keys Button Presses.....	31
3.1.8	Door Guard Not Working Properly.....	31
3.1.9	Power Reset Button is Not Working .....	32
3.1.10	Spindle Does Not Turn ON.....	32
3.1.11	Pendant Does not Respond and Appears to be Locked Up .....	32
3.1.12	E-Stop Error (Machine Is Disabled).....	32
3.1.13	Touchscreen Does Not Respond.....	32
3.1.14	USB Not working on Pendant.....	33
3.1.15	LAN Port Not working on Pendant .....	33
3.1.16	Axis Fault .....	33
3.1.18	Homing Error - Axis, Tool Turret .....	34
3.2	Problems Relating to Machining Results.....	34
3.2.1	Poor Finish .....	34
3.2.2	Turning Diameters Out of Round .....	35

3.2.3	Cutting Taper .....	35
3.2.4	Parts Have Incorrect Dimensions .....	35
3.2.5	Threading Problems.....	36
3.5	Problems with the Machine Tool.....	37
3.5.1	Spindle Stalls or Turns-Off During Machining .....	37
3.5.2	Spindle Motor Hums or Will Not Run .....	37
3.5.3	Spindle Runs Backwards .....	37
<b>4.0</b>	<b>Diagnostics .....</b>	<b>38</b>
4.1	The Machine Tool & Set up .....	38
4.1.1	Leveling .....	38
4.1.2	Lubrication .....	38
4.1.3	Machine Set up.....	38
4.2	The Mechanical Drive Train (X,Z) .....	39
4.3	Pendant and Computer Module Diagnostics.....	40
4.4	Motor Diagnostics.....	41
4.4.1	Cable Connections .....	41
4.5	Servo Drivers .....	42
4.6	Electrical.....	43
4.6.1	Checking A/C Voltage.....	43
4.6.2	Checking Fuses.....	43
4.6.3	Main Electrical Enclosure .....	43
4.6.4	Computer Module Connections .....	43
4.6.5	Cable Connections .....	44
4.7	Door Switch .....	45
4.8	Service Codes .....	45
4.8.1	Software Codes .....	45
4.8.2	Machine Set-Up Codes .....	46
4.8.3	Diagnostic Codes .....	47
4.8.4	Operator Defaults/Options Codes.....	48
<b>5.0</b>	<b>Procedures for Replacements &amp; Maintenance .....</b>	<b>50</b>
5.1	Replacements .....	50
5.1.1	Brushless Motor Replacement.....	50
5.1.2	Servo Drive Replacement .....	50
5.1.3	Program Panel Assy and Computer Module Replacement .....	51
5.1.4	Updating the Program Panel and Computer Module Software .....	52
5.1.5	Cable Routing on Machine & In Electrical Cabinet .....	52
5.1.6	Electronic Handwheel and ESTOP switch replacement.....	53
5.1.7	Spindle Drive Belt Replacement .....	53
5.1.8	Spindle Encoder Replacement.....	53
5.1.9	Spindle Motor Replacement.....	53
5.1.11	Spindle Motor Wiring.....	53
5.2	Maintenance .....	54
5.2.2	Calibration & Backlash Constants.....	54
<b>6.0</b>	<b>Turret.....</b>	<b>56</b>
6.1	Troubleshooting the Turret.....	56
6.1.5	Warranty Issues .....	56
<b>7.0</b>	<b>Introduction to Self-Service .....</b>	<b>57</b>
7.1	When You Have a Service Problem.....	57
7.1.1	Communication with the SWI Customer Service Group.....	57
7.2	Replacements .....	57
7.2.1	Exchange Program.....	57
7.2.2	Return Material Authorization (RMA) Number .....	57
	<b>TRAK Warranty Policy .....</b>	<b>58</b>

**List of Figures**

Figure 2.7a and b – Lifting and/or Moving the Machine .....12

Figure 2.11 - RLX – Machine ID Key .....21

Figure 2.14a – Auxiliary Output Connectivity.....23

Figure 2.14b – Auxiliary Output Example of Air Blast .....24

Using a calibrated O.D. micrometer with .0001" graduations, measure and record the generated dimension at a 6.00 spacing. The acceptable measurement of parallelism of spindle axis to carriage movement (taper of test piece) is .0008" over 6". If the taper measured is not acceptable, re-machine the test part and/or check and adjust the level of the machine, and/or adjust the headstock alignment. Figure 2.19 TRAK TC2 Lathe - Test Part .....25

Figure 4.5a Motor Servo Driver Fault Errors .....42

Figure 4.5b Motor Servo Driver Fault Errors .....**Error! Bookmark not defined.**

Figure 5.1.2 - Servo Drive and Motor Replacement & Part List .....51

Figure 5.1.3.2 – Program Panel & Computer Module Replacement .....52

Figure 5.1.3.2 – Program and Run Panels, Computer Module Replacement.....52

# TRAK Machine Tools Reference Page

Use this page to log your machine's Model and Serial Number, as well as your Login credentials for [buytrakparts.com](http://buytrakparts.com). For additional manuals visit [www.trakmt.com](http://www.trakmt.com). For additional machine drawings not found in this manual, visit [www.buytrakparts.com](http://www.buytrakparts.com).

## Machine Model & Serial Number

The plate below is for you to write down your model and serial number. Keep this info handy for when you contact Customer Service.

<b>TRAK MACHINE TOOLS</b>	
	<b>SOUTHWESTERN INDUSTRIES, INC.</b>
2615 HOMESTEAD PLACE, RANCHO DOMINGUEZ, CA 90220	
MODEL	<input type="text"/>
S/N	<input type="text"/>
THIS UNIT HAS _____ POWER SOURCE(S) ELECTRICAL RATINGS:	
<input type="text"/> 60	VOLTS <input type="text"/> AMPS <input type="text"/> 3 PHASE Hz
<input type="text"/> 60	VOLTS <input type="text"/> AMPS <input type="text"/> 1 PHASE Hz
FLA OF LARGEST MOTOR <input type="text"/> AMPS	
SHORT CIRCUIT CURRENT RATING <input type="text"/> AMPS	
ELECTRICAL DRAWING #:	<input type="text"/>
MACHINE (ONLY) MADE IN TAIWAN	

# 1.0 Safety Requirements

The safe operation of the ProtoTRAK TC2RX CNC depends on its proper use and the precautions taken by each operator.

- Read and study the TRAK TC2 ProtoTRAK RLX CNC Safety, Programming, Operating, and Care Manual. Be certain that every operator understands the operation and safety requirements of this machine **before** its use.
- Read and study the TRAK TC2 Safety, Installation, Maintenance, Service & Parts List Manual. Be certain that every operator understands the operation and safety requirements of this machine **before** servicing.
- Always wear safety glasses and safety shoes.
- Always stop the spindle and check to ensure the CNC control is in the stop mode before changing or adjusting the tool or workpiece.
- Never wear gloves, rings, watches, long sleeves, neckties, jewelry, or other loose items when operating, or around the machine.
- Use adequate point of operation safeguarding. It is the responsibility of the employer to provide and ensure point of operation safeguarding per ANSI B11.6-2001.

## 1.1 Safety Publications

Refer to and study the following publications for assistance in enhancing the safe use of this machine:

**Safety Requirements for Manual Turning Machines with or without Automatic Control (ANSI B11.22-2002 (R2020)). Available from the American National Standards Institute, 1819 L Street N. W., Washington, D.C. 20036.**

**Concepts And Techniques Of Machine Safeguarding (OSHA Publication Number 3067). Available from The Publication Office - O.S.H.A., U.S. Department of Labor, 200 Constitution Avenue, NW, Washington, DC 20210.**

All other regulations are specific to the State in which the machine is installed.

## 1.2 Danger, Warning, Caution, and Note Labels and Notices as Used In This Manual

**DANGER** – Immediate hazards that **will** result in severe personal injury or death. Danger labels on the machine are red in color.

**WARNING** – Hazards or unsafe practices that *could* result in severe personal injury and/or damage to the equipment. Warning labels on the machine are gold in color.

**CAUTION** – Hazards or unsafe practices that *could* result in minor personal injury or equipment/product damage. Caution labels on the machine are gold in color.

**NOTE** – *Call attention to specific issues requiring special attention or understanding.*

## **Safety & Information Labels Used on the TRAK TC2RX Lathe**

*It is forbidden by OSHA regulations and by law to deface, destroy or remove any of these labels.  
TRAK TC2RX Danger, Warning, Caution, and Note Labels and Notices Listed Below:*

 **CAUTION**

**Do not operate this spindle at a higher RPM than rated by the chuck manufacturer. Set the maximum RPM limit in the ProtoTRAK DRO mode. Take special precautions with chucks that have four or more jaws and unbalanced parts.**

**S-S2191**

 **WARNING**

- 1. Bars may only protrude beyond this point if adequate additional guarding and support is provided.**
- 2. Do not extend material beyond the spindle without suitable guarding.**

**S-S2141**



 **SAFETY INSTRUCTIONS** 

1. Read and understand the Operator's Manual and all warnings on this sign before operating machine.
2. Machine should only be operated by qualified personnel that have been trained in the operation and use of this machine.
3. Machine starts and moves automatically. Never place any part of your body near or on moving parts of this machine.
4. Stop spindle completely before touching the tool, work piece, or spindle.
5. Do not operate machine unless all guards, interlocks, and safety devices are installed and functioning.
6. Always clamp work piece and tool securely. Avoid excessive feeds and spindle speeds.
7. Wear safety glasses, shoes, and hearing protection when operating machine.
8. Remove rings, watches, jewelry and loose fitting clothes. Keep hair away from moving parts of the machine.
9. Installation and service must be performed by qualified personnel only, following instructions in the Maintenance Manual. Turn off and lock-out the power at the main electrical panel before servicing.
10. It is the responsibility of the user to be sure that this machine is in safe operating condition at all times, and that the operator follows the safe operating procedures described in the Operator and Maintenance Manuals.

**Do not remove or disfigure this sign.** S-S1140

**AC208V**  
S-S1109

 **AC480V**

 **CAUTION**

1. Air pressure must be between 6 - 7kgf/cm<sup>2</sup> (85psi-100psi).
2. Filter and Lubricator must be maintained once a week.
3. Recommended Air line - 12mm (1/2 inch).

S-S2050

**WARNING**



1. Isolate power before removing covers.
2. High speed belt and pulley inside! Do not touch moving parts.
3. Failure to comply with the above may result in serious injury.

S-S2040

 **SAFETY WARNING!** 







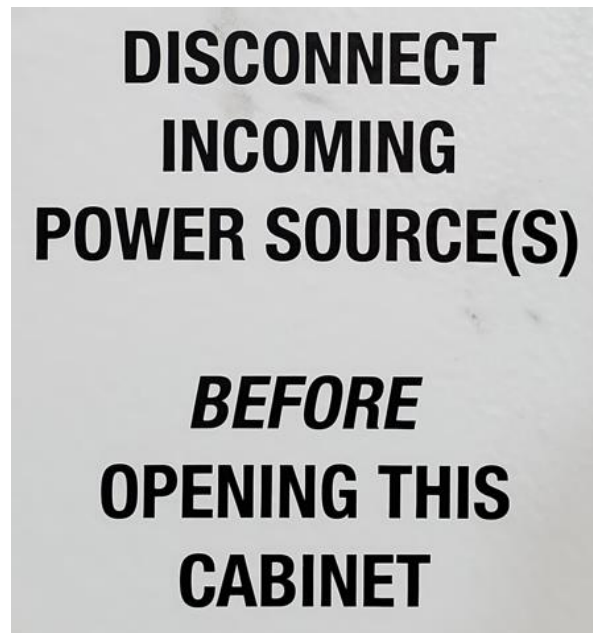

1. Hazardous voltage present in the electrical equipment of this machine. Only qualified engineers are allowed to install, test, adjust or maintain it.
2. Isolate power before install, test, adjust or maintain the electrical equipment of this machine.
3. Do Not turn on the power before the protective grounding has been securely connected.
4. Do Not change any device of this machine without permission.
5. Residual, hazardous voltages remain after the power is disconnected. Wait 10 minutes after removal of power before undertaking any work on the electrical equipment of this machine.

**FAILURE TO COMPLY WITH THE ABOVE  
MAY RESULT IN A SERIOUS ACCIDENT** S-S1071





 <p><b>Eye protection must be worn</b></p>	 <p>Do not touch moving chuck or parts.</p>	<p><b>WARNING</b></p>  <p>Never open door during operation. Do not operate with door open / removed. Flying objects can cause injury or death.</p>
 <p>Read and understand operator's manual and all other safety instructions before using this machine.</p>	 <p>Crush hazard. Keep hands clear when opening / closing door.</p>	<ol style="list-style-type: none"> <li>1. Do not tamper with any safety devices.</li> <li>2. This equipment should only be operated by qualified personnel that have been trained in the operation and use of this equipment.</li> <li>3. This machine is automatically controlled and can start at any time. Keep clear of all moving parts.</li> </ol> <p><b>FAILURE TO OBSERVE THE ABOVE INSTRUCTIONS MAY CAUSE SERIOUS PERSONAL INJURY OR MACHINE DAMAGE.</b></p> <p>S-S2340</p>

### 1.3 Safety Precautions

**WARNING!**

**Use only chucks which are rated to the maximum RPM of the lathe.**

1. Do not operate this machine before the TRAK TC2 ProtoTRAK RLX CNC Programming, Operating and Care Manual has been studied and understood.
2. Read and study this TRAK TC2 Safety, Installation, Maintenance, Service & Parts List Manual. Be certain that every operator understands the operation and safety requirements of this machine **before** servicing.
3. Do not run this machine without knowing the function of every control key, button, knob, or handle. Ask your supervisor or a qualified instructor for help when needed.
4. Protect your eyes. Wear approved safety glasses (with side shields) at all times.
5. Don't get caught in moving parts. Before operating this machine, remove all jewelry, including watches and rings, neckties, and any loose-fitting clothing.
6. Keep your hair away from moving parts. Wear adequate safety headgear.
7. Protect your feet. Wear safety shoes with oil-resistant, anti-skid soles, and steel toes.
8. Take off gloves before you start the machine. Gloves are easily caught in moving parts.
9. Remove all tools (wrenches, chuck keys, etc.) from the machine before you start. Loose items can become dangerous flying projectiles.
10. Never operate any machine tool after consuming alcoholic beverages, or taking strong medications, or while using non-prescription drugs.
11. Protect your hands. Stop the machine spindle and ensure that the CNC control is in the STOP mode:
  - Before changing tools
  - Before changing parts
  - Before you clear away the chips, oil or coolant. Always use a chip scraper or brush.
  - Before you make an adjustment to the part, chuck, coolant nozzle or take measurements.
  - Before you open safeguards (protective shields, etc.). Never reach for the part, tool, or fixture around a safeguard.
12. Protect your eyes and the machine as well. Don't use a compressed air hose to remove the chips or clean the machine (oil, coolant, etc.).
13. Stop and disconnect the power and lock-out/tag-out the machine before servicing, changing belts, pulley, gears, etc.
14. Keep work area well lighted. Ask for additional light if needed.
15. Do not lean on the machine while it is running.
16. Prevent slippage. Keep the work area dry and clean. Remove the chips, oil, coolant and obstacles of any kind around the machine.
17. Avoid getting pinched in places where the spindle, carriage, cross slide or sliding door create "pinch points" while in motion.
18. Securely clamp and properly locate the workpiece in the chuck or in the fixture. Use proper tool holding equipment.
19. Use correct cutting parameters (speed, feed, and depth of cut) in order to prevent tool breakage.
20. Use proper cutting tools for the job.
21. Prevent damage to the workpiece or the cutting tool. Never start the machine (including the rotation of the spindle) if the tool is in contact with the part.

22. Don't use dull or damaged cutting tools. They break easily and may become airborne. Inspect the sharpness of the edges, and the integrity of cutting tools and their holders.
23. Large overhangs on cutting tools when not required result in accidents and damaged parts.
24. Prevent fires. When machining certain materials (magnesium, etc.) the chips and dust are highly flammable. Obtain special instruction from your supervisor before machining these materials.
25. Prevent fires. Keep flammable materials and fluids away from the machine and hot, flying chips.
26. Do not rotate the spindle by hand unless the Red Emergency Stop button is pressed.

## 2.0 Installation

Read and understand this entire installation section before beginning the installation procedure.

### 2.1 Floor Plan, Layout & Space Requirements

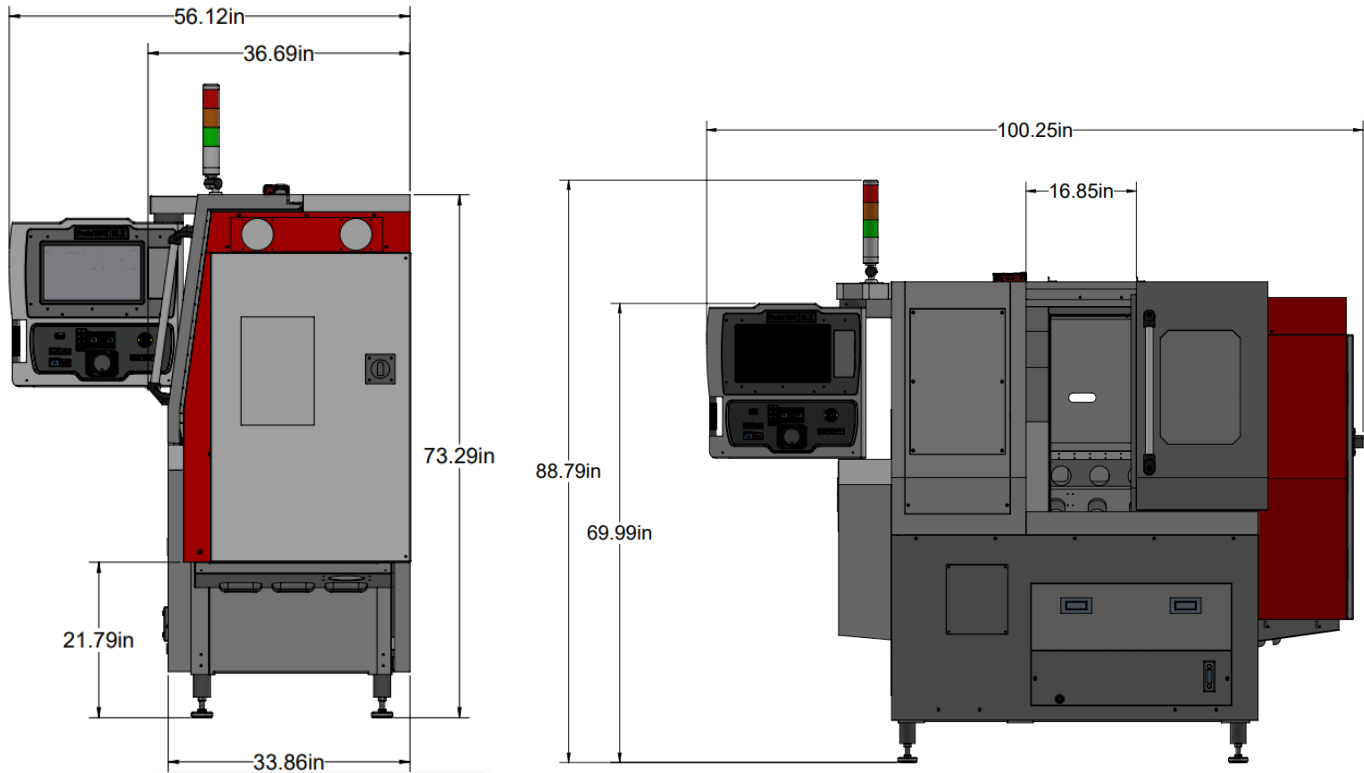

SIDE VIEW

FRONT VIEW

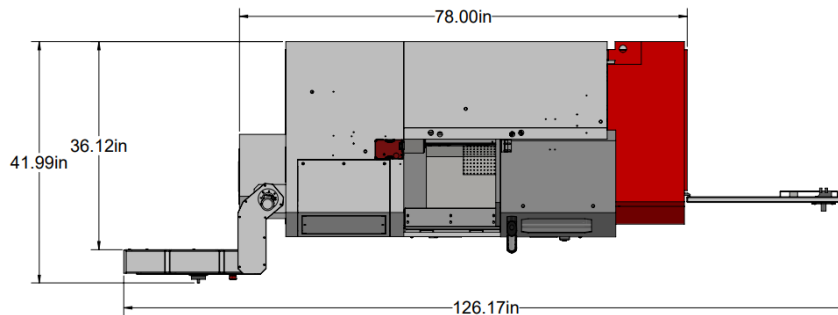

TOP VIEW

## TC2

OVERALL LIMITS	Max. Swing over bed	12 in
	Max. Turned diameter / Length	8 in / 11 in
	High speed – Hydraulic power chuck/ 5C High torque – Manual chuck	6 in 8 in
TRAVEL	X Axis – direct drive with brake	8.25 in
	Z Axis – direct drive	11.40 in
SPINDLE	Spindle nose	A2-5
	Spindle power	7.5 HP
	High speed option - Spindle speed (1:1.5)	4000 rpm
	High torque option - Spindle speed (1:2)	2500 rpm
	Lubrication	Grease
	Spindle thru bore	2.40 in
	Bar capacity	2.06 in
FEED RATE	Traverse rate max. (X, Z-axis)	600 in/min
TURRET	No. of tool station	8
	Type	Block – Std.
	Tool max size	¾ in
	Tool index / Clamping method	Servo motor/ Pneumatic
COOLANT SYSTEM	Capacity	15.8 gal
	Coolant pump	1/8 HP
GENERAL SPECIFICATION	Overall dimensions (L×W×H)	70 in x 34.6 in x 70 in
	Gross weight (approx.)	3200 lbs, 3500 lbs with hydraulic
POWER REQUIREMENTS	Electrical, (see section 2.9)	208V, 3P, 60 Hz 480V, 3P, 60 Hz
	Pneumatic, Min.	90 PSI
Ball Screw	X-axis Pitch	6mm
	Z-axis Pitch	6mm

## 2.2 Uncrating

Carefully remove the wood crate and protective packaging, paying attention not to scratch, damage, or mar any parts of the machine.

To take the machine off the pallet, loosen and remove the screws and nuts holding the machine to the wood pallet.

## 2.3 Lifting and/or Moving the Machine

**CAUTION!**  
**Proper equipment of sufficient capacity must be used when lifting and/or moving the machine.**

Do not remove the pallet from the machine until it is brought to its final location!



Once the pallet has been removed, the machine can be moved using a forklift or a pallet jack rated for 5500 lbs.



For proper operation, the machine should be set on a substantial floor capable of supporting the weight safely.



When using a forklift, adjust the forks to line up with two "Lift Here" labels (or wider) see photo below.

When using a standard width pallet jack (rated for a minimum of 5500 lbs.) slide the jack in-line with "Lift Here" labels (from front or the back of the machine) see photo below-



**Figure 2.7a and b – Lifting and/or Moving the Machine**

**ATTENTION!**

**Immediately report, in writing, any damage observed at this time that can be attributed to the transportation or improper handling/moving of the machine.**

Once machine is placed in the desired location, remove following three (Red) shipping brackets:

1. Remove the Door shipping bracket

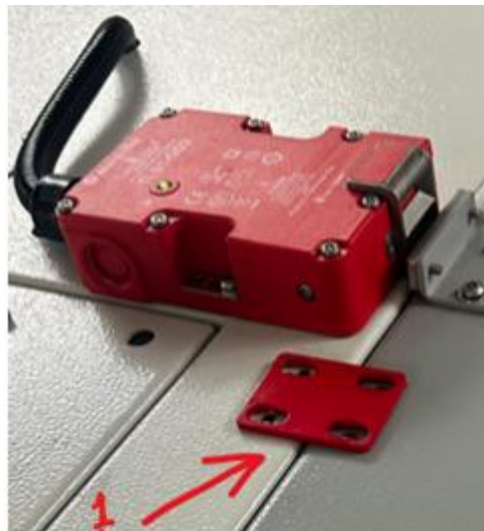

2. Remove the Pendant shipping bracket.



3. Remove the Z-axis shipping bracket (located behind the back panel with dual handles).

**Note 1: After the shipping brackets have been removed, Do Not reinstall the back covers. Lubrication checks and machine leveling must be completed before these covers are reinstalled.**

**Note 2: Do not discard these three shipping brackets if there is a chance that the machine will be transported to another facility in the foreseeable future. These brackets must be used to prevent machine damage during transportation.**



4. Mount the door handle (shipped inside the chip tray)

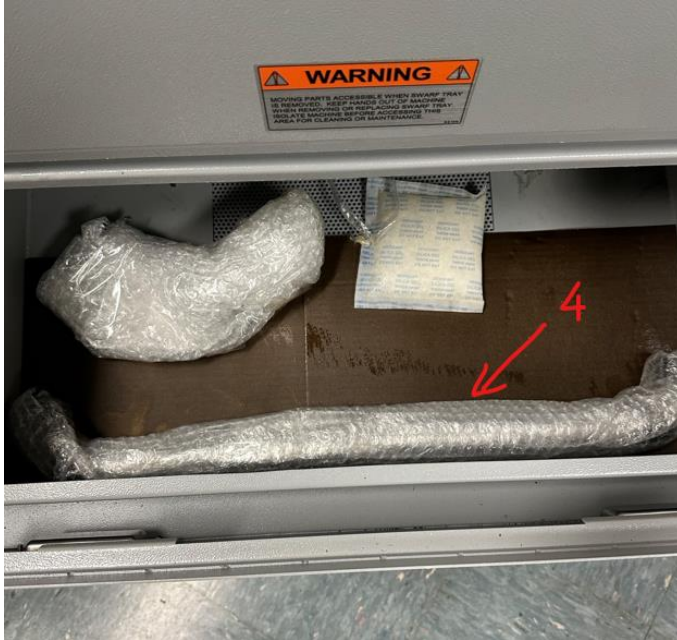

5. Reposition pendant arm and mount the bottom pivot support (shipped inside the chip tray) - Remove the top cover on the pendant arm then remove four arm mounting screws and rotate the arm 180 degrees to the front and reinstall the top cover.

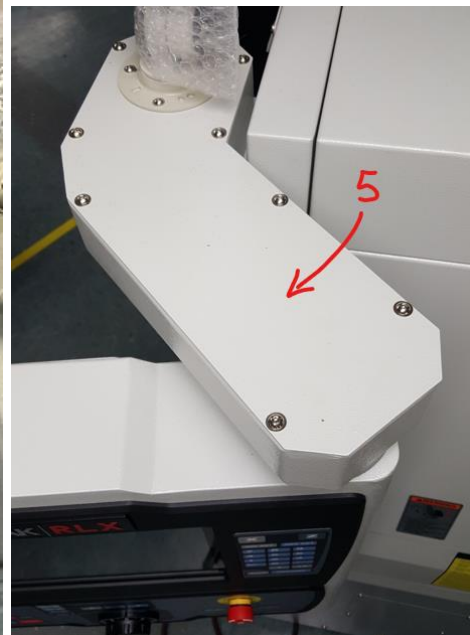
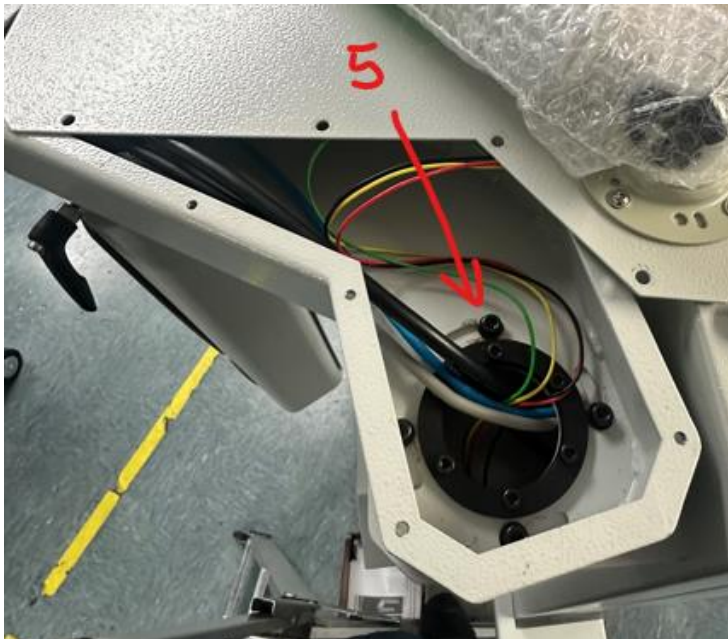



6. Install Pendant bottom pivot/support bracket (bracket is shipped inside the chip tray). Use a torpedo level and adjust the bottom (and if necessary the top arm) to make the pendant is as plumb as possible front-to-back and side-to-side.

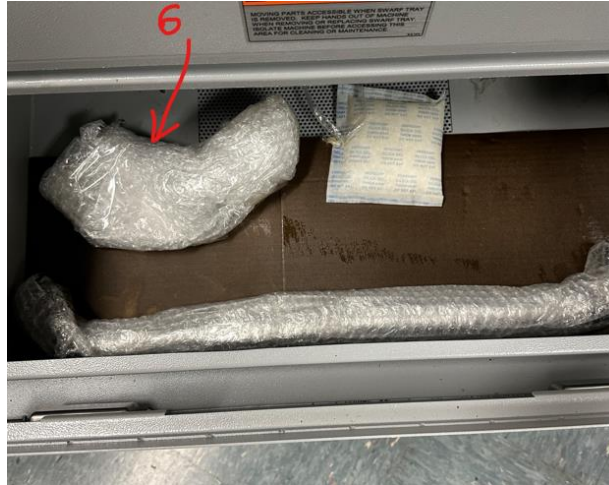

## 2.4 Shortages: Inventory Checklist

- \_\_\_\_\_ Door Handle (34433)
- \_\_\_\_\_ Pendant bottom mounting bracket (Item 6 in picture above)
- \_\_\_\_\_ TRAK TC2 Safety, Operation & Programming Manual (P/N 35007)
- \_\_\_\_\_ TRAK TC2 Safety, Installation, Maintenance, Service & Parts List Manual (P/N 35006)

In case of shortages, contact the representative from whom you purchased the machine.

## 2.5 Installation Instructions & Checklist

Installer: Use this checklist to ensure a complete set-up of the TRAK TC2 Lathe.

1.	<input type="checkbox"/>	Turn OFF the main power switch.
2.	<input type="checkbox"/>	Remove all shipping brackets (see section 2.3, steps 1, 2, and 3).
3.	<input type="checkbox"/>	Visually inspect wiring going into the electrical panel. Visually verify the wiring is correct per our wiring diagram. Make sure a strain relief is being used where the wiring enters the cabinet. Have the customer repair any wiring discrepancies.
4.	<input type="checkbox"/>	Clean the machine if needed and remove any remaining grease.
5.	<input type="checkbox"/>	Rotate the pendant and install bottom support bracket (see section 2.3 steps 5 and 6), make sure the pendant swivels easily and locks in place using torque handle.
6.	<input type="checkbox"/>	Slide the front door back and forth to make sure it slides smoothly.
7.	<input type="checkbox"/>	Remove the protective plastic cover from the door window.
8.	<input type="checkbox"/>	Ensure that the main power cord is plugged in. Turn ON the main power switch
9.	<input type="checkbox"/>	Push Power Reset button and Home the machine. Verify that the machine homes properly and soft limits are functioning. To test soft limits, use the electronic handwheel at the fastest setting.
10.	<input type="checkbox"/>	Check that the oil reservoir in the oil pump is at the max level.
11.	<input type="checkbox"/>	Lubricate all the linear rails and the ball screws. Under service codes press code 300 to operate the lube pump.
12.	<input type="checkbox"/>	With the two back covers removed, check to make sure that the linear rails and ball screws have a light but visible sign of oil coating.
13.	<input type="checkbox"/>	Position the saddle approximately to the center of the bed for leveling.
14.	<input type="checkbox"/>	With the two back covers removed, remove the accessory leveling plate stowed/mounted on the right side of the upper casting and mount it to the top of the saddle casting (left end), and level the machine. The machine should be level to within 0.0008" longitudinally (along Z-axis) and 0.0005" transversely (along the X-axis). Make any necessary adjustments. For more details on where to locate the levels, see section 2.8.
15.	<input type="checkbox"/>	To run the spindle, maximum RPM must be set in DRO mode. Run the spindle at maximum RPM and verify that it reaches the maximum specified speed for the machine option.
16.	<input type="checkbox"/>	Enter DRO and check turret tool changer functionality by setting every tool location to make sure that it works in all positions.
17.	<input type="checkbox"/>	Open and close the door and verify the door switch is functional. The control should display a message of "DOOR GUARD OPEN" in DRO mode when the door is open, and it should disappear when the door is closed. Test the door lock functionality. Push the door lock button and verify if the door lock engages. Push the door lock button again to release the lock.
18.	<input type="checkbox"/>	In DRO mode, make sure the X and Z buttons and front panel electronic handwheel are functional. Press the electronic handwheel button and select an axis button then move the handwheel clockwise to move. Reverse by moving counterclockwise. Select each resolution button separately and recheck. Test both axes.
19.	<input type="checkbox"/>	Enter DRO, Turn ON the spindle, move an axis using handwheel, then press the E-Stop button and verify the machine has commanded the spindle to decelerate and not coast to stop, and X and Z axis no longer have power to move.
20.		Use the accessory key on the pendant. Make sure the coolant pump turns on. The accessory key should be in the ON position in DRO to test it.
21.	<input type="checkbox"/>	Cut the test part to check for taper. Measure the test bar and make any machine adjustments. If unacceptable taper is found, re-check the level before attempting to adjust the headstock.
22.	<input type="checkbox"/>	Reinstall the two back covers and wipe down the machine to finish.
<b>Options checklist</b>		
		If the machine came with the Hydraulic Chuck option installed see section 2.19 for details and check the following:
23.	<input type="checkbox"/>	Verify the hydraulic tank and chuck pressures are set correctly according to the labels on the machine

24.	☐	<p>The chuck foot pedal/switch will be shipped in a box along with the machine. Place the foot pedal on the floor in a location that is convenient for the operator. Connect the pedal cable under the Electrical cabinet (connector is located under the front-right corner of the box). Check the operation of the pedal to make sure that it operates properly.</p> 
		<p style="text-align: center;"><b>CAUTION!</b></p> <p style="text-align: center;"><b>If the TC2RX Lathe has a chuck already mounted on the spindle, make sure the chuck is mounted properly and that all the mounting screws are torqued to spec. Also, make sure that the chuck jaws are closed against themselves or onto a piece of material before turning on the spindle and running the machine.</b></p> <p style="text-align: center;"><b>If the chuck was not purchased from SWI, check to make sure the chuck is rated for the maximum rpm of the machine. If it is not, do not run the machine above the chuck's maximum rated rpm.</b></p> <p style="text-align: center;"><b>The chucks purchased from SWI are rated for the machine's maximum rpm.</b></p>

## 2.6 ProtoTRAK RLX Control Hardware

- 2-axis CNC, 2-axis DRO, 8 tool servo-controlled turret
- Intel® 2 GHz or faster PC-based processor
- 4 GB of RAM or higher
- 32 GB or larger mSATA SSD (solid state) memory drive
- 15.6" color LCD for clear presentation of prompts, status information and part graphics
- Touch screen activated graphical menus with context configured touch keys.
- LED status lights built into run panel.
- 4 USB ports (plus 1 for the options key as a USB drive)
- 2 Ethernet Ports (1 for the control system and 1 for the user)
- Polycarbonate sealed membrane and gasket sealed control enclosure to lock out contamination.
- Feedrate override of programmed feedrate and rapid.
- Spindle Control (FWD, REV, OFF) keys
- Coolant and AUTO mode in RUN mode
- Programmable Spindle Speed
- Feed STOP and GO keys
- Speed override of programmed spindle speed
- Power Reset Button
- Modular design simplifies service and maximizes uptime.
- Home switches for the X and Z-axes are installed to set software limits and prevent crashes.
- Electronic handwheel on the pendant for X and Z-axes
- Fast, Course, Fine and Ultrafine EHW resolution control
- D.C. Servo Motors rated 28.2 in-lbs continuous torque (with brake) for X axis, and 28.2 in-lbs for the Z-axis.
- Precision ground balls screws in the carriage and cross slide to ensure smooth accurate contours without backlash.

## 2.7 Cleaning

1. Remove rust protective coating from the machine
2. The coating is best removed with clean, dry rags. Do not use a cleaning solution that may damage the rubber way scrapers, plastic parts, or paint.

### **WARNING!**

**Do not use gasoline or other flammable cleaning agents for cleaning the machine.**

3. Be certain the carriage, cross slide and spindle move freely and smoothly over their entire length.

## 2.8 Leveling

The precision and durability of the lathe depends on it being leveled properly. Final inspection can be done only when the machine has been correctly leveled. For the complete leveling procedure, please refer to our Dozuki "TC2 Leveling Procedure".

It is important that the lathe be level to produce accurate work. **Note:** *The use of a precision level having a minimum accuracy of .0005" over 10.0" will be required.*

To prepare the machine for leveling first remove the two top rear panels. With the machine powered up, enable the servos and move the X Axis in the negative direction to the soft limit and then move the Z Axis in the negative direction to where the turret is over the chuck jaws. This puts the X and Z carriages near the center of the machine base – see image below.





## 2.8.1 Leveling

1. To level the machine from side-to-side, place the precision level on the precision machined surface on top of the casting, (approximately in the middle) as shown below.

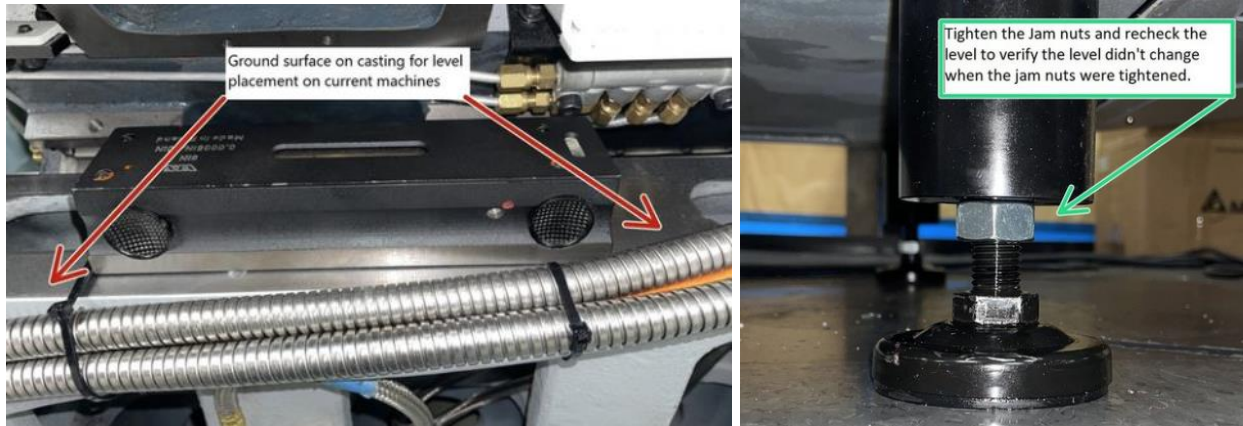

Adjust the side leveling feet\* on each end until the machine is level side-to-side. Move the level from end to end, to make sure that the level of the machine does not change.

**\* When leveling the machine adjust the leveling feet to be as low as possible but still have a 3.5" gap between the bottom of the machine and the floor, to minimize vibrations during operation and provide space for a pallet jack or fork lift.**

2. To level the machine front-to-back, remove a special leveling plate from the back of the top casting – see image for the location. Move the carriage along the Z axis to approximately the middle of travel and mount the leveling plate on the left end of the top casting – see image below.



3. After machine is leveled front-to-back, recheck the side-to-side to make sure nothing changed.



## 2.9 Electrical Connection

### DANGER!

Be certain that 208-volt electricity (typical range 208 – 240V) is used only with a machine labeled 208 volts at the electrical cabinet on the cabinet power entry.

Be certain that 480-volt electricity (typical range 432 – 528V) is used only with a machine labeled 480 volts at the electrical cabinet on the cabinet power entry.

### WARNING!

480 Volts will damage expensive electrical components if the TC2RX machines marked for 208V are wired by mistake to 480 volts. That damage is not covered under warranty.

### DANGER!

The 208-240 volt or 432 to 528 volt line must originate from a dedicated and independent overcurrent protected/fused box with a manual shut-off lever. It is the responsibility of the purchaser to supply a wired box that meets all local codes and regulations.

#### Power Requirements at 208 Volts, 3-phase 60 Hz

Model	Full-load Amp of Machine	Full-load Amp of Largest Motor
TC2RX	42	27

#### Power Requirements at 480 Volts, 3-phase 60 Hz

Model	Full-load Amp of Machine	Full-load Amp of Largest Motor
TC2RX	25	13.5

**TRAK MACHINE TOOLS**  
 SOUTHWESTERN INDUSTRIES, INC.  
 2615 HOMESTEAD PLACE  
 RANCHO DOMINGUEZ, CA 90220

MODEL   
 S/N

THIS UNIT HAS  POWER SOURCE(S)  
 ELECTRICAL RATINGS:

VOLTS  AMPS  PHASE  
 Hz

VOLTS  AMPS  PHASE  
 Hz

FLA OF LARGEST MOTOR  AMPS  
 SCCR NOT MORE THAN   
 RMS SYM AMPS  V MAX

ELECTRICAL DWG #:

MACHINE (ONLY) MADE IN TAIWAN

TC2 machine is equipped with a power cable terminated with a circular 3-phase power plug. The cable to the TC2RX machine enters the electrical cabinet on the back of the machine. The cable leads to the main on/off breaker switch through a strain relief fitting on the top of the cabinet enclosure. The ground wire should be connected at the top of the breaker bracket. Breaker bracket is equipped with grounding screws marked with ground symbols.

**DANGER!**  
**Only a qualified electrician should wire the 208-240 or 432-528 volt 3-phase electricity.**

Southwestern Industries recommends the machine be earth grounded by driving a copper rod into the ground. It is the responsibility of the customer to install this rod.

## 2.10 Phase Converters

For those machines that will be run with a phase converter, it must be a CNC rated rotary type rather than a static phase converters. CNC rated rotary phase converters allow for varying loads in the system. A CNC rated phase converter also regulates the new leg created so it does not end up being too high or low of a voltage. The electrical load on the machine will vary based on the type of cut taken and the speed of the motor. Static phase converters can only be used on machines with a non-varying load. Please contact your local phase converter distributor for precise sizing and follow the machine power requirements listed above in section 2.9.

## 2.11 Air Connection

The TC2 TRAK machines have an air hookup on the left side of the machine.

The minimum air supply line to the machine should be 1/4" hose, preferably 3/8" hose if air gun is used while machine is running. The air regulator pressure is set to 90 psi at the factory for the turret unit. The minimum air flow rate required to operate the turret properly is 10 SCFM.

**CAUTION!**  
**Make sure the main power switch is turned off at the electrical cabinet before plugging in the cables.**

## 2.12 Machine ID Key

Ensure that the Machine ID key is plugged into the port on the computer module inside the electrical cabinet, or the machine will not run. There are two types of machine ID keys – one for low and one for high-speed models. The ID can be confirmed in service code 33.

**CAUTION!**  
**Make sure the main power is turned off on the back of the electrical cabinet before plugging in the ID key.**

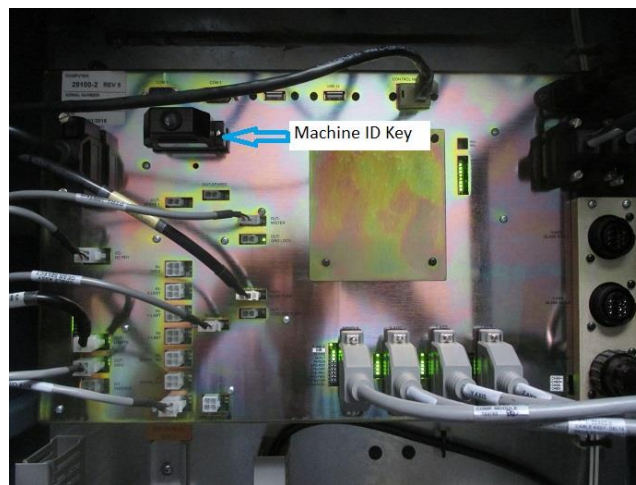

**Figure 2.11 - RLX – Machine ID Key**

## 2.13 Pendant Maintenance

### 2.13.1 How to Clean the Touchscreen

When cleaning the touchscreen, make sure to turn off the machine. You can use any window cleaning solution to get any debris off of the screen. It is preferable to use a non-lint cloth when cleaning.

**Note:** *If you clean the screen with the power on, you may get false triggering or no touchscreen detection at all.*

## 2.14 Lubrication

The lube pump is controlled by the machine's software.

### 2.14.1 Lube Pump Operation

The pumping output is regulated electronically to control the Interval Time between pumping cycles, and the Discharge Time of each pumping cycle. The pump can also be run manually through a key found under service codes. The following describes the steps used to program the lube pumps Interval and Discharge times.

Start with using Service Code "E".

- **To manually Pump Oil:** Service Code 300  
Press "Mode", "Set up", "Service Codes", press "E", and then press Code 300 (Lubrication Pump Switch). The pump will pump oil for the amount of time programmed in Code 302. The spindle does not need to be turned on.
- **Setting Interval Time:** Service Code 301  
Press "Mode", "Set up", "Service Codes", "C" (Machine Setup), Code 301, and then enter the desired Interval time in minutes.
- **Setting Discharge Time:** Service Code 302  
Press "Mode", "Set up", "Service Codes", "C" (Machine Setup), Code 302, and then enter the desired Discharge time in seconds.

### 2.14.2 Factory Default Values

Interval Time - 30 min

Discharge Time - 4 sec

Discharge Pressure - Approximately 100 - 150psi

To adjust the amount of Discharge Pressure displayed on the lube pump gauge, loosen the jam nut and turn the adjustment screw located on the top right side of the lube pump while the lube pump is activated. To activate the lube pump use Service Code 300.

#### **CAUTION!**

**Failure to properly lubricate the lathe will result in the premature failure of ball screws and linear rails.**

#### **CAUTION!**

**Failure to manually activate the pump at the beginning of each day, or allowing the Auto Lube to run dry may cause severe damage to the lathe linear rails and ball screws.**

## 2.15 Auxiliary Output

An Auxiliary Option Kit P/N 29600-4 is offered for the support +24VDC optional devices. Power and device control are provided via the following terminal block found on a DIN rail in right section of the electrical cabinet.

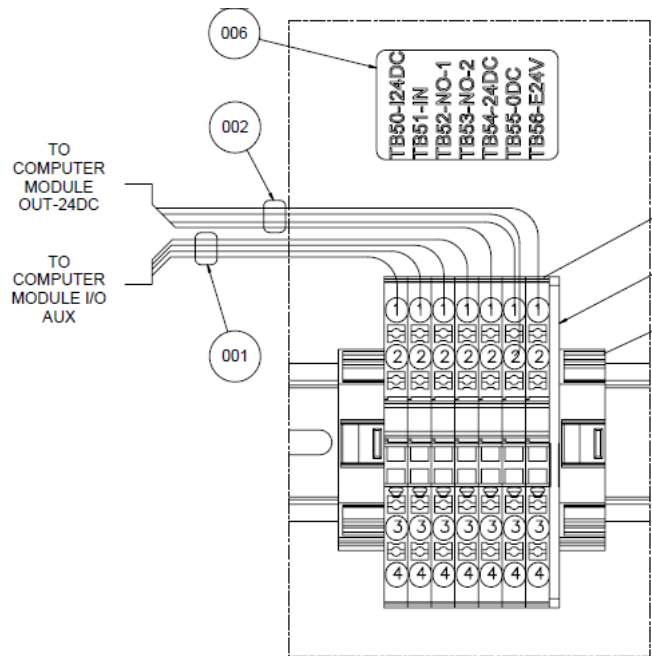

**Figure 2.14a – Auxiliary Output Connectivity**

The Auxiliary Output control is a Normally Open (NO) contact. It is rated for 30 volts DC or AC for current of up to 1 amp. This is provided via terminals TB52-NO-1 and TB53-NO-2 as shown in the above figure. Terminal blocks TB54-24DC and TB55-0DC provide access to 24 Volt power at all times, when the machine is on. It is rated for 1 amp. This Auxiliary power can be used to power a 24V Relay/Solenoid or other device through the Auxiliary Output contact. In addition, the TB56-E24V provides 1A of 24V power that depends on ESTOP and could be used for ESTOP control of external devices if needed.

An Air Blast Solenoid is an example device which could be used with this Auxiliary Output Option. Auxiliary 24V will be turned OFF and ON via the Auxiliary Output when programmed with the AUX event.

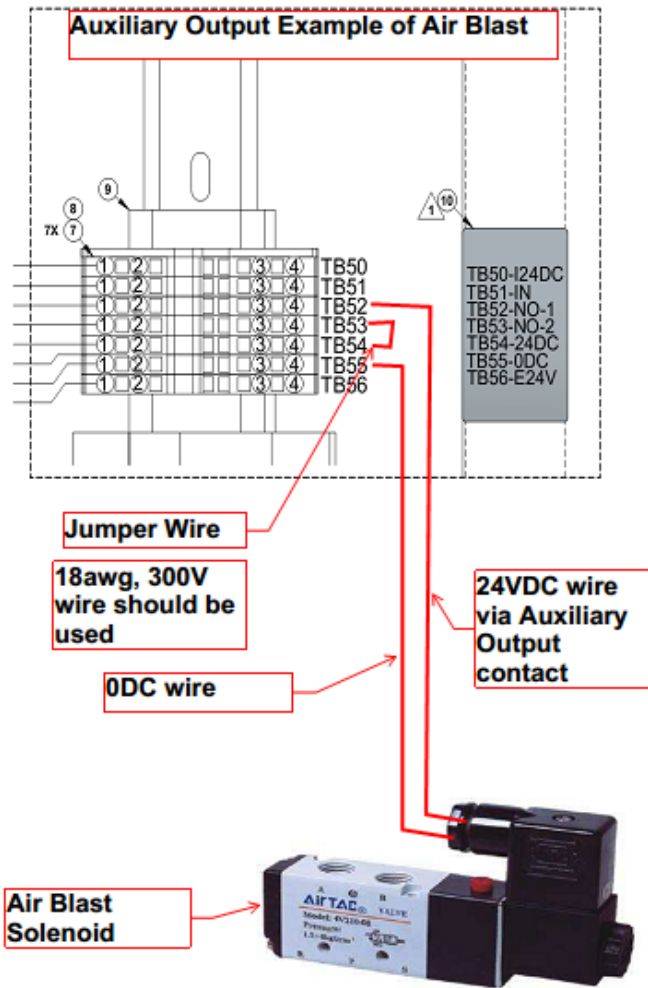
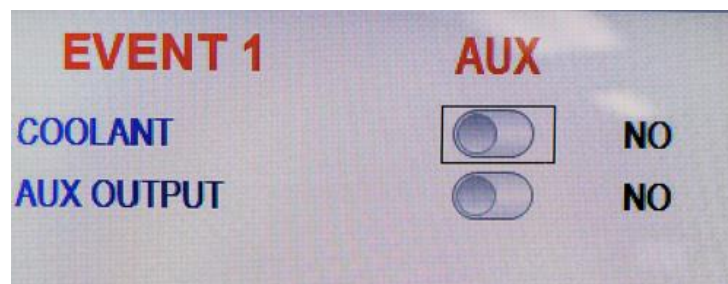

**Figure 2.14b – Auxiliary Output Example of Air Blast**

**Note:** The Auxiliary Output relay is overwritten by the E-stop and/or Fault circuit. It will deactivate the relay whenever there is an E-stop condition or when the software shuts OFF all the outputs due to a fault condition.

This Auxiliary Output Option is enabled on the control system via the hardware Options Key. When enabled, the Status screen will show a status of "Yes" for the Auxiliary Output. The use of code 318 will also show the "Auxiliary Output" highlighted when enabled.

This software option turns on the AUX event and gives the user 2 outputs as shown below.



## 2.16 Cutting the Test Part

(See Figure 2.19)

### Tools Required:

- Chuck
- right-hand face and turn type

In order to accurately machine the test part, the bearings in the spindle must be properly warmed and preloaded. This is accomplished by running the spindle for 5 to 10 minutes prior to cutting the test bar at 500 RPM.

Load an approximately 2" dia. aluminum bar into the spindle chuck. Load a standard right hand face and turning tool into a tool turret. Set the depth of cut to a maximum of 0.002".

Set the spindle to an acceptable speed for turning the test piece. A speed range from 650 to 950 RPM is recommended.

## 2.17 Measurement of the Test Part

### Tools Required:

- O.D. Micrometers with .0001" graduations

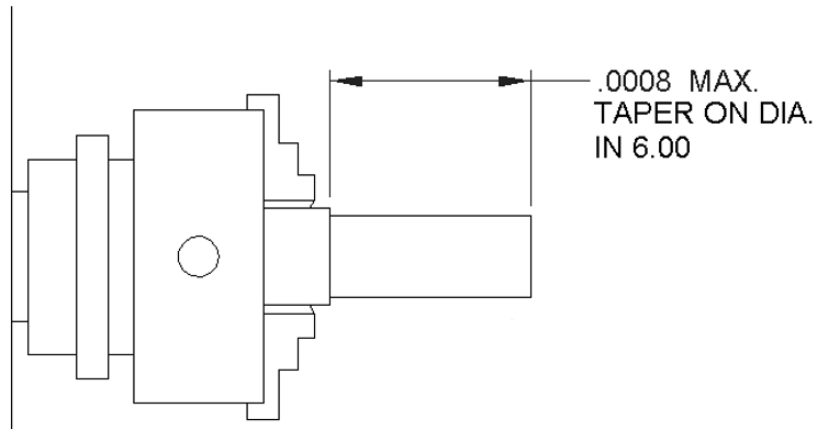

Using a calibrated O.D. micrometer with .0001" graduations, measure and record the generated dimension at a 6.00 spacing. The acceptable measurement of parallelism of spindle axis to carriage movement (taper of test piece) is .0008" over 6". If the taper measured is not acceptable, re-machine the test part and/or check and adjust the level of the machine, and/or adjust the headstock alignment. See Figure above

## 2.18 Mounting of a Buck (or TRAK/Accutek) Zero Set Chuck- RX Lathe

### WARNING!

The Buck and TRAK chucks require a certain amount of torque to be properly mounted to the A2-5 adapter plate. Please use 58 ft-lbs to torque six M10 faceplate mounting screws, and three M10 chuck mounting screws and check the chuck torque occasionally. Improper installation of the chuck could result in injury or death.

Bolt the chuck adapter plate to the spindle with (6) M10 SHCS. The round pin/key on the spindle orientates the adaptor.

Then bolt the chuck to the adaptor plate with (3) M10 SHCS that come with the chuck.

**Note:** Chucks that are installed in the field may require balancing of the spindle assembly. Chucks ordered and installed at the factory will come balanced as an assembly. It will be the responsibility of the end user to balance chucks purchased and installed in the field.

**Tools required:**

- Magnetic base with a 0.0001" dial indicator
- Chuck wrench
- Allen wrench 3/8"
- Allen wrench 5/16"
- Alignment bar
- Lift for chuck
- Turning tool with insert

## Procedure:

**Note:** *This procedure needs to be performed after the spindle taper test.*

1. Clean the face and inside taper of the adapter plate.
2. Install the adapter plate onto the spindle.
3. True the adapter plate to the spindle.
4. Install the chuck.
  - a. Using lift, raise the chuck and locate against the backing plate.
  - b. Rotate spindle until the holes in the chuck align with the holes in the backing plate
  - c. Install the 3 M10 screws and remove the lift.
5. Trueing the chuck.
  - a. Snug the 3 bolts in the face of the chuck to prevent the chuck from slipping.
  - b. Adjust the 4 fine adjustment set screws around the periphery until they contact the adapter plate and then back out one turn.
  - c. Open chuck and clean jaws thoroughly
  - d. Install alignment bar so there is approximately 6" protruding from chuck.
  - e. Using your indicator and the 4 fine adjustment set screws, adjust the chuck until the alignment bar is running within 0.0005" 1" from chuck.
    - i. While adjusting the set screws, rotate the spindle so the set screws align with the indicator.
  - f. Move the indicator 6" from chuck and check runout. Max. runout is 0.0015"
  - g. Tighten 3 screws in face and 4 set screws as required to obtain these readings.
  - h. Torque the 3 screws in the face of the chuck to 47 ft-lbs
  - i. You will need to go from the 1" from the chuck and 6" from the chuck multiple times to obtain 0.0005" at 1" from chuck and 0.0015" 6" from chuck.
  - j. Place your indicator on the outside diameter of the chuck and measure the total runout. Maximum runout of the chuck body cannot exceed 0.004".
  - k. Remove alignment bar.
  - l. Using a die grinder and a 1/4" round nose double cut carbide burr, make a small mark on the spindle for orientation. See photo 4 and 5
  - m. Using a stamp, make a mark on the adapter plate for clocking of chuck when it is removed and then re-installed onto spindle. See photo 4 and 5.



Photo 4



Photo 5



**WARNING!**

**Use only chucks which are rated to the maximum RPM of the lathe.**

## 2.19 Machines with Hydraulic Chuck option installed.

### 2.19.1 Hydraulic System

TC2 machine with Hydraulic Chuck option comes with a self-contained hydraulic system.

It is used to control the operation of the hydraulic chuck. The main system pressure regulator indicated by arrow in the green box (see left photo), can be set to anywhere between 370 and 480 psi, as indicated on the label above the gage in red box, (see center photo).

Chuck pressure is set using regulator knob below the chuck pressure gage, indicated by arrow on the right photo. The maximum setting is 260 psi, as indicated on the label above the gage.



### 2.19.2 Removing Hydraulic 3 Jaw Chuck

1. Unclamp the chuck and press the E-Stop in the center of travel.
2. Remove 2 of the 3 jaws from the chuck.
3. Using the remaining jaw to hold the chuck in place loosen all 6 screws holding the chuck to the spindle face.
4. Remove the last jaw from the chuck.
5. Remove chip cover from the center of the chuck.
6. Attach lifting eye bolt and hoist the chuck to take pressure off the drawtube and nut.
7. Remove the 6 screws holding the chuck.
8. Unscrew draw nut by hand, you may need to adjust the hoist until the nut rotates by hand.

### 2.19.3 Reinstalling Hydraulic 3 Jaw Chuck

1. Clean off all the mounting surfaces and threads with WD40 and use an air blast to remove any chips.
2. Use a fine grit deburring stone to check for dings or high spots on the mounting faces.
3. Apply anti seize to the threads and mounting screws.
4. Set the draw tube to the mid travel position and E-stop the machine.
5. Using the eyebolt on the chuck, hoist it into position and align with the draw nut with the drawtube.
6. Screw the draw nut by hand until it is approximately  $\frac{3}{4}$  engaged on the drawtube thread.



7. Align the chuck body holes to the holes on the spindle face and hand tighten the 6 screws.
8. Remove the hoist so the chuck is supporting itself.
9. Attach one jaw to the chuck and use it to torque the 6 mounting screws to 58 ft lbs.
10. Remove the jaw again from the chuck and thread the draw nut until it bottoms against the bottom of the drawtube thread.
11. Reinstall the chip cover and all three jaws to the chuck so the chuck is ready for operation.

#### **2.19.4 Installing Collet Chuck**

1. Clean off all the mounting surfaces and threads with WD40 and use an air blast to remove any chips.
2. Use a fine grit deburring stone to check for dings or high spots on the mounting faces.
3. Unclamp the draw tube and thread the draw nut of draw tube until it reaches the face.
4. Back the nut out ¼ turn.
5. Clamp the drawtube and place the collet chuck in position lining the chuck body holes to the holes on the spindle face.
6. Attach the 6 mounting screws and torque to 58 ft lbs.

#### **2.19.5 Installing Collet**

1. Move drawtube to the extended (open) position.
2. Insert pins of collet installation tool into holes on face of collet and compress collet.
3. Take note of where keyway is located on collet.
4. Insert collet firmly into chuck aligning key with keyway and release installation tool.

### **2.20 Cabinet Heat Exchanger**

The purpose of the cabinet heat exchanger is to cool the electrical cabinet and internal components. The unit is mounted on the electrical cabinet door. It is powered by single phase 220VAC and is protected by fuses F14 & F15, which also protect the enclosure fan, resistor fans and door fan. The fans are active only when the machine is enabled. Estop switch activation disables the fans. The heat exchanger is equipped with a washable filter. There is a small tab at bottom of filter to remove. The filter media should be cleaned on a weekly basis with either an air gun or soapy water. A quick check to ensure fans are operating is to place a piece of paper against fan from outside, the fan should pull the paper toward the fan.

## 3.0 Troubleshooting by Symptom

Use this section to begin the process of resolving a service problem. Each problem type is described in a few words and then more fully described in an explanatory paragraph. Following this is a chart that directs in the most logical steps.

### 3.1 Problems Related to the Pendant and Computer Module

#### 3.1.1 Pendant will not Connect to Motion Control in Computer Module at Boot Up

This symptom can happen during boot up or when the machine was connected it may disconnect and you may see a flashing message on the screen.

Possible Cause	Check This
Ethernet Cable Not Properly Connected	Windows error "There is a problem with the network adapter: Media Disconnected" will show on the screen for a cable issue.  Check the Ethernet cable is properly connected to both the Program Panel Assembly and Computer Module (disconnect and reconnect)  Ensure the Program Panel side is the proper Ethernet port (lower connector, closer to the bottom of Pendant)
Need to Power Cycle the control system	Try rebooting the machine to solve the problem
Recent changes to the network or network settings	Review settings and return to original status to see if this solves the issue
Windows OS does not see the network connection	In the Windows Control Panel, view the Network and Sharing Center. The Connection diagram should show the network connection. Replace the network cable to see if the network connection is found.
Failed programming panel	Replace the Program Panel Assembly if none of the above resolve the issue (P/N 31601-1)

#### 3.1.2 Pendant will not Connect to Motion Control in Computer Module

This symptom can happen during boot up or when the machine is connected. The unit may disconnect and a flashing message on the screen and a Fault Message such as "Unable to communicate with Motion Control..."

Possible Cause	Check This
Start with troubleshooting in the previous section.	Power cycle the Pendant/Computer Module.  Replace the Computer Module if the same Error and Fault persists. (P/N 29100-10)

### 3.1.3 Pendant Does Not Power On

This issue may be caused by a lack of power to Program Panel Assembly inside the Pendant assembly.

Possible Cause	Check This
No Power to the Program Panel Assembly	Check the I/O Cable (DB25 Connector) cable is connected to both the Program Panel Assembly and the Computer Module. Disconnect the cable and verify there are no bent pins or sockets pushed out of position in the connectors.
No Power on the Computer Module	On the Computer Module, check the status LED labeled +24VDC next to the I/O Cable from the Pendant. If the LED is off, check the power input to the Computer Module.
Power Problem in the Program Panel Assembly	On the rear of the Program Panel Assembly, review the Status LED group. All three of the power LEDs should be on: 24VDC, 12VDC and 5VDC. If one or two of the LEDs are not ON, replace the Program Panel Assembly.

### 3.1.4 Screen Problems

#### 3.1.4.1 Screen is Blank but LCD is Visible

To check for this symptom, use a flashlight to see if you can see our software running in the background. This means that the Program Panel Assembly needs to be replaced.

Possible Cause	Check This
LCD Backlight Issue	Use a flashlight to shine light on the LCD screen. If character/graphics can be seen, the Program Panel Assembly should be replaced.
Power Problem in the Program Panel Assembly	On the rear of the Program Panel Assembly, review the Status LED group. All three of the power LEDs should be on: 24VDC, 12VDC and 5VDC. If one or two of the LEDs are not ON, replace the Program Panel Assembly.

#### 3.1.4.2 Bad Picture on the Display

The display has strange characters, horizontal bars or other unfamiliar images, or the display continually rolls.

Possible Cause	Check This
Poor cable connection in Program Panel Assembly	Check Power LEDs as in 3.1.4.1 Replace Program Panel Assembly if issue is not resolved.

### 3.1.5 RSG Button Does Not Work

Possible Cause	Check This
RSG Connection	Disconnect the RSG and confirm the pins/sockets on the connectors of the RSG and Pendant are not bent or pushed in. Reconnect the RSG. RSG connector is located on the bottom of the Pendant assembly.
Internal Pendant Issue	Jumper across the two metal sockets on the RSG connection on the bottom of Pendant. Review the D9 LED status "RSG" on the rear of the Program Panel Assembly OVERLAY interface board. The LED should be ON. If this is not the case, replace the Program Panel Assembly.

### 3.1.6 System Does Not Respond to Numeric Keys Button Presses

The Numeric Keys are the keys to the right of the LCD screen. (This does not include the keys below the screen.)

Possible Cause	Check This
Software not seeing the Key Press	Press any of the numeric keys. Confirm the "Key Press" D3 LED in the status LEDs group on the rear of the Program Panel Assembly OVERLAY interface board is ON while the key is pressed. If this does not happen, power cycle the machine and repeat. Perform the next test below.
Keypad not functioning	Use Service Code 81 to determine if any the keys are not functioning. Replace the Program Panel Assembly if any keys are non-functioning or intermittent functionally.

### 3.1.7 System Does Not Respond to Critical Keys Button Presses

The Critical Keys overlay is found below the touchscreen.

Possible Cause	Check This
Software not seeing the Critical Key Press	Press any of the numeric keys. Numeric keys work but critical keys don't – replace the Run Panel and recheck. If numeric keys also don't respond - confirm the D3 LED in the status LEDs group on the rear of the Program Panel Assembly OVERLAY interface board is ON while the key is pressed. Power cycle the machine and repeat. If D3 LED does not respond to any of the key presses – replace the Program Panel Assembly.

### 3.1.8 Door Guard Not Working Properly

Possible Cause	Check This
Switch Connection Issue	Check the door guard is connected to the Computer Module P60-IN DOOR SWITCH. Disconnect and reconnect. Power cycle the Computer Module. Use Service Code 521 to see all the inputs. Verify DOOR SWITCH status upon guard closing. Replace door switch if necessary.
Internal Issue	With the door guard closed, verify LED Status of P60-IN DOOR SWITCH is ON. If this is not working, jumper across the input on the Computer Module. If this LED does not come On or the "DOOR OPEN" message persists, replace the Computer Module.

### 3.1.9 Power Reset Button is Not Working

The power reset button must be pressed to energize the servos and spindle. This must be done upon power up or following the use of the E-Stop button or whenever an M abort (critical fault) message happens.

Possible Cause	Check This
E-Stop Engaged	Disengage the E-Stop button and repeat using the Power Reset Button. Check E-STOP cable connection on the back of Program Panel Assembly OVERLAY interface board.
Fault Messages	Attend to and clear any displayed Fault Message
Keypad Issue	Refer to Critical Keys Issues Above in Section 3.1.7
	Power cycle the unit. If all above do not resolve the issue, call customer service.

### 3.1.10 Spindle Does Not Turn ON

The user presses the FWD or REV buttons on the pendant and the spindle does not come on.

Possible Cause	Check This
Invalid User Mode for Spindle Control	Check the User Mode, Verify the E-Stop is not actuated
Axis Fault	Confirm if can jog each axis.
Keypad Issue	Refer to Critical Keys Issues Above
	Power cycle the unit. If all above do not resolve the issue, call customer service.

### 3.1.11 Pendant Does not Respond and Appears to be Locked Up

During normal operation, one of the follow symptoms occurs so that the Pendant is non-responsive;

- No BEEP when any button is pressed or touch screen is pressed
- Screen does not change when touched
- USB Keyboard does NOT respond.
- Pressing E-stop Stops the axis but Pendant does not change screen.
- Numeric Key press does not cause the Key Press LED to turn ON.
- Disconnecting network cable from Computer module does not change Lock-up condition.

Possible Cause	Check This
Pendant Non-Responsive	Reboot control and see if problem goes away. If it does, continue to operate. If the problem returns, replace the Program Panel Assembly.

### 3.1.12 E-Stop Error (Machine Is Disabled)

The E-Stop turns the power off to the axis and spindle motors. On the RX control system, the message that is displayed when a user presses the E-Stop button is as follows: "Servos not enabled – Please press power reset button on the front panel to enable the servos".

Possible Cause	Check This
E-Stop Switch Failure	Confirm E-Stop is not engaged. Verify ESTOP cable connections to Program Panel Assembly Overlay PCB board. Confirm D7 D8 are ON and D24 and/or D25 LEDs are not lit up. Replace the ESTOP switch.

### 3.1.13 Touchscreen Does Not Respond

This means when the user presses the screen, there is no feedback from the touchscreen. When the touchscreen is working properly, every touch of the screen produces a noticeable "touch dot" on the screen.

When you see this touch dot, it means the operating system sees the touch. If this touch dot is not present then the OS has not seen it nor has our software.

Possible Cause	Check This
Internal connection Issue	Verify the touch screen USB controller located on the back of the Program Panel Assembly is connected to the motherboard with a black USB cable. Reconnect the cable. A "touch dot" should appear on the screen where contact with the screen is made. For touching the softkeys, a beep is generated by the Pendant on touching the key. (The info area of the screen does not generate a beep sound.) Power cycle the machine. If the problem persists, replace the Program Panel Assembly.

### 3.1.14 USB Not working on Pendant

When plugging in a USB device the control does not recognize it.

Possible Cause	Troubleshooting Procedure and Possible Causes
Device Driver Not Installed	Device driver not installed for USB device. Run service code 540 and load USB driver.
One single USB or all USB connections are not working with any device	For a previously working USB port, and no device functions using the port, power cycle the control system. If the problem persists, replace the Program Panel Assembly.
USB Manufacturer	SWI recommends only the brand and model it offers to the customers.
USB Drive Full	Check for free space remaining on the drive.

### 3.1.15 LAN Port Not working on Pendant

Symptom	Troubleshooting Procedure and Possible Causes
No network connectivity	For either of the network ports not functioning, disconnect and reconnect both ends of the cable. Reboot control and see if problem persists. Repeat with a new, known good cable. If the problem persists, replace the Program Panel Assembly.

### 3.1.16 Axis Fault

Perform the following Service Codes and procedures:

- **Code 33** Software Identification. This is needed if you call SWI Customer Service.

The following symptom has to do with the servo drive showing a fault number on the digital LED. See section 4.5 for a list of fault codes for the servos. Trouble shoot based on the error seen on the servo.

Symptom	Troubleshooting Procedure and Possible Causes
Servo cables at Computer Module lose or disconnected.	Check cable connections, especially the encoder cable to the motor, both ends of cable. If the cable was loose or had a poor connection, fix problem and power cycle the machine.
Excessive friction in the slideways	See Machine Tool & Setup Section 4.1
Binding or looseness in the Drive Train	See Mechanical Drive Train (X, Z) Section 4.2
Incoming electrical power	Incoming voltage. See Electrical Section 4.6
Servo Drive failure	See Servo Driver - Section 4.5
Motor failure	See Motor diagnostics, Section 4.4
Computer/Pendant failure	See Computer/Pendant diagnostics, Section 4.3 Error code 96(X-axis) or 98(Z-axis)

	(NFLT) LED on the computer module is for that particular axis is OFF
	Error occurs when going into DRO mode or Run mode
	Error is displayed on the Drive all the time even after power reset.

### 3.1.18 Homing Error - Axis, Tool Turret

The homing function is a very critical function that locates and identifies the absolute machine zero position, where all other positions and offset are derived from. This function is to be performed every time the system has been turned on or reset. The homing function will move X and Z axis in the positive direction as much as it can. Home Switches are installed on the carriage and cross slide and inform the control system that the axes are close to a hard stop. Each Home Switch is placed approximately 1½ turns of a ball screw from the hard stop. During homing an axis moves towards the home switch and once the switch is reached, the axis then reverses and backs off about half a turn until the encoder Index position is found. At that moment the control sets the 0 on DRO and we call it home position. Turret homing is a move to find tool position number one. Homing function sequence is Z and X and Turret. Problems related to home switch functionality or Turret homing should be referred to qualified personnel. If you see an error related to homing please contact TRAK for service.

**Critical Error 185:** Z Home switch failed to open. Check to make sure that the switch is working properly.

Figure 3.1 Home function failure example.

## 3.2 Problems Relating to Machining Results

### 3.2.1 Poor Finish

Poor finish can be caused by a number of variables including: speeds, feeds, tooling, machine setup and chatter.

Perform the following Service Codes:

- **Code 33** Software Identification. This is needed if you call SWI Customer Service.
- **Code 128** Enter backlash compensation.

Possible Cause	Check This
Inadequate or no Lubrication to Ballscrews or linear guides	Make sure all the linear guides are getting proper lubrication. If not, check to make sure that the lube pump is functioning properly. Also check for any pinched or blocked oil lines.
X & Z-axis Drive Trains are loose	Check Repeatability using the Repeatability and Positional Accuracy procedure. Step by step, carefully inspect the Drive Train for any looseness. It may be necessary to disassemble and then reassemble the Drive Train. See Mechanical Drive Train (X, Z) Section 4.2
Linear guides are excessively worn	Visually check the condition of all the linear guides. For machines that may have excessively worn linear guides they may need to be replaced. Check lubrication to affected areas.
Machine set-up problem	Machine's feet are not equally supporting weight. See Leveling, Section 2.8. Verify the tool holder is correctly centered to the dead center of the spindle.

Possible Cause	Check This
Tooling problem	Improper tooling, tool sticking out more than 1.5 times the shank size. Work piece not properly supported, speeds too fast, feeds too slow. See Machine Tool & Setup, Section 4.1
Loose bearing problem	Looseness in the spindle bearings. Call for service as the spindle cartridge may need to be replaced. Ball screw misalignment. See Mechanical Drive Train (X, Z), Section 4.2.
Poor Thread Finish	Use Service Code 510 to verify the encoder count matches the RPM selected on the Pendant

### 3.2.2 Turning Diameters Out of Round

Parts are not round within 0.0002". Runout for the spindle is best measured by using a .0001" dial indicator and mounting to the inside taper of the spindle. Rotate the spindle and measure the indicator movement.

Perform the following service code and procedures:

Possible Cause	Check This
Tooling problem	Improper tooling, workpiece not properly supported. See Machine Tool & Setup, Section 4.1
Loose bearing problem	Looseness in the spindle bearings. See Mechanical Drive Train (X, Z), Section 4.2. Spindle bearing not preloaded correctly. Call for service as the spindle cartridge may need to be replaced.

### 3.2.3 Cutting Taper

Parts are considered to be cutting on a taper if there is a difference in diameter of more than .0008" over 6 inches. This is best measured by using a .0001" micrometer.

Possible Cause	Check This
Machine set-up problem	Machine not leveled properly See Leveling - Section 2.8
Tooling problem	Improper tooling; Work piece not properly supported. Reduce overhang from chuck headstock.
Misalignment of ball screw	See ball screw adjustment - Section 4.2
Loose bearing problem	Looseness in the spindle bearings. Call for service as the spindle cartridge may need to be replaced.
Headstock not aligned	Adjust Headstock for Taper

### 3.2.4 Parts Have Incorrect Dimensions

Parts are being machined with dimensions that are different than those programmed. Typical accuracy expectations should be:

- The acceptable measurement of parallelism of spindle axis to carriage movement is .0008" over 6 inches.



### 3.2.4.1 Every Part Has the Same Error

Possible Cause	Check This
Programming Error	Programmed dimensions not correct. Check absolute and incremental values.
Machine & Setup Related	See Machine Tool & Setup - 4.1

### 3.2.4.2 Errors are Random or Accumulate in Size over the Part Run

Possible Cause	Check This
Machining Setup	See Machine Tool & Setup - 4.1
Looseness in the Drive Train, ball nut loose in yoke, split nut loose, yoke loose	See Mechanical Drive Train (X, Z) - 4.2

### 3.2.5 Threading Problems

Threads can be cut with an unlimited number of pitches and up to 10 leads.

To reduce the relief area when threading up to a shoulder the spindle speed should be reduced as much as possible. The slower the speed of the spindle, the closer the cutting tool can come to the end of the programmed thread before it pulls out and retracts. If a nut must be turned all the way up to a shoulder, machine a relief area behind the last thread.

**Note:** *No machine can thread up to a shoulder and instantaneously pull out.*

Perform the following service code and procedure:

- **Code 510** Spindle encoder test

#### 3.2.5.1 Cross Threading

Threaded parts are cross-threaded after completion of the threading event.

Possible Cause	Check This
Looseness in the drive train	The drive train Diagnostics See Mechanical Drive Train (X, Z) - Section 4.2
Failure of the spindle encoder Run service code 510 to check if the encoder counts.	Replace spindle encoder See Spindle Encoder replacement - Section 5.1.8

#### 3.2.5.2 Not Threading

The machine will not cut a thread at all.

Possible Cause	Check This
Spindle speed too fast	Slow down spindle speed.
Failure of the spindle encoder Run service code 510 to check if the encoder counts.	Replace spindle encoder See Spindle Encoder replacement - Section 5.1.8
Broken or slipping encoder coupling	Check and replace as necessary
Encoder Disk or Reader Head on motor are loose	Swap the motor in question with a known good motor. If the symptom stays with the motor in question, then replace the motor. If not, then the motor is not at fault and something else is causing the problem.

## 3.5 Problems with the Machine Tool

### 3.5.1 Spindle Stalls or Turns-Off During Machining

During machining, the spindle turns off and loses power. First check incoming voltage and connections.

Possible Cause	Check This
Machine Tool and Setup problem	Check the type of material being cut, type and size of cutting tool, RPM, and Feed rate. Also check the condition of the cutter to verify that the cutter is not dull. See Machine Tool & Setup Section 4.1
Motor drive Belt is slipping	Check the alignment, condition, and tension of the Drive Belt.
Cut more than the machine is capable	Check speeds, feeds and depth of cut
Spindle Drive Thermal Overload Relay has tripped	IOUT - Current Out (located on the Spindle Drive). When the Overload Relay is enabled, an "oL1" error occurs shutting off the Spindle Drive. The harder the Spindle Motor works trying to make heavy cuts, the more current the Spindle Motor utilizes. This can be caused by a cut so large that it exceeds the machine capability, or a problem with the spindle motor or AC drive.
Spindle Drive parameters are not correct	May need to re-download the Spindle Drive parameters. Contact Customer Service for assistance.

### 3.5.2 Spindle Motor Hums or Will Not Run

The spindle motor makes a constant humming noise during operation or will not turn on.

Possible Cause	Check This
Wrong voltage	Check the 208V voltage to the machine
Poor wiring connections	Check all the wiring connections to the electric's box.
Defective cable connections	Check all cable connections
Spindle Motor is bad	Check the resistance of the Spindle Motor windings on the Spindle Motor between L1 & L2, L2 & L3, and L1 & L3, using an Ohmmeter. The resistance should range from "0.4 to 0.5 Ohm". If the Ohmmeter reads "0 Ohms" or "OL", then replace Spindle Motor. Next, check the resistance between L1 & Ground, L2 & Ground, and L3 & Ground, using an Ohmmeter. The resistance should read "OL". If not then replace Spindle Motor.

### 3.5.3 Spindle Runs Backwards

The spindle motor runs in the opposite direction. The spindle should always spin in the counterclockwise direction as viewed from the right side end of the lathe when the forward key on the pendant is pressed.

Possible Cause	Check This
3-Phase wires backwards	Need to switch any 2 of the 3 wires either coming out of the Spindle Drive (T1, T2, and T3) or going into the Spindle Motor (U, V, and W). <b>Caution:</b> <i>Be sure to shut off all power to the machine before attempting to switch any wires.</i>

## 4.0 Diagnostics

This section explains the diagnostic procedures used to isolate service problems.

### 4.1 The Machine Tool & Set up

#### 4.1.1 Leveling

Leveling is one of the most important aspects of setting up the machine properly. Improper leveling can lead to a variety of machining problems.

The machine should be level to within .0008" longitudinally and .0005" transversely. See Leveling Procedures, Section 2.8.

#### 4.1.2 Lubrication

Lubrication is one of the single, most important maintenance issues and plays a key role in assuring the performance and durability of the lathe. At the beginning of each day manually supply oil to the way surfaces by doing Service Code 300.

Lack of lubrication can lead to a variety of problems with your machine motion due to increased friction in the sliding ways. This increased friction may lead to part inaccuracies and decreased life expectancies of your ball screws and way surfaces.

#### 4.1.3 Machine Set up

The machining set-up itself is always something that can greatly influence the performance of the lathe. The following are some things to keep in mind.

<b>Problems With</b>	<b>Can Contribute To</b>
Feed and Speeds (spindle rpm) See below	Poor finish Excessive speeds and feeds can break cutting tools or wear out too fast.
Tooling Using the wrong cutter for an application	Poor finish Parts incorrect
Cutting too deep	Part dimensions incorrect Driving and cutting forces cause deflections, since no material is totally rigid
No coolant	Poor finish, decrease the life of the cutter

The following is a list of common machining problems and some possible solutions.

<b>Problem</b>	<b>Check or Try This</b>
Poor surface finish	Dull tool Reduce feedrate Increase spindle speed Use a higher rake angle tool Make sure tool is not dull or chipped Use proper grade of cutting tool Use coolant Check to see if tools are on the centerline
Workpiece out of taper	Check headstock alignment
Excessive chatter	Tool bit improperly ground or not on center Avoid extreme negative rake inserts Tool overhang too great, tool deflection Improper feeds and speeds Work improperly supported

#### 4.1.3.1 Spindle Speeds

Spindle speeds are influenced by a number of variables:

- Material
- Rigidity of the Machine Setup
- Coolant
- Insert, geometry and material of insert
- Depth of cut

#### 4.1.3.2 Feedrates

Factors that affect feedrates:

- Depth of cut
- Design or type of insert
- Sharpness of the insert
- Workpiece material
- Type of finish or accuracy required

## 4.2 The Mechanical Drive Train (X,Z)

Indications:

- Troubleshooting instructions indicate that the drive train is potentially the problem and other, more easily checked, variables have been exhausted.
  - Roughness, looseness, tightness or jamming movement in the carriage or cross slide.
  - Carriage walk-up due to Z ball screw misalignment.
1. The torque required to manual turn the X and Z-axis ballscrews should be between 10 to 15 in-lbs. These values should be consistent in both directions and along all areas of the axis travel. Values that differ from that of above may correspond to misaligned ball screws.

The following steps take you in logical sequence through the assemblies. If the step doesn't isolate or resolve the problem, it will be necessary to disassemble the indicated item and move to the next step.

1. Ensure that the screws that hold the bearing housing in place are not loose.
2. Ensure that the Clamp Nut is secured. The following applies to the clamp nut: When loosening, make sure to back out the 10-32 screw from the clamp nut.
3. When tightening, drag the 10-32 screw to keep the clamp nut from spreading, tighten it again after the clamp nut is tight. Torque the 10-32 screw to 90 in-lbs. Torque the clamp nut to 50 ft-lbs.
4. Take out the angular contact bearings in the X & Z-axis and inspect them. They should roll smoothly and be lightly greased. If not, replace them. The Z-axis has 2 bearing housings. One housing is on the drive train side with the other on the support housing.

**Note:** *The bearing housing and spacer rings are matched sets - keep them together.*

1. With the motor and drives removed, inspect the ball screw, ball nut and yoke for the potential problems shown in the chart below.

<p style="text-align: center;"><b>CAUTION!</b> <b>Unlike a leadscrew, do not unscrew the ball screw from its nut. This will destroy the ball screw!</b></p>
---

Potential Problem	Check By
Bad ball screw	<ul style="list-style-type: none"> <li>• Visual inspection of the ball nut - if the nylon seal is broken or deformed, if contamination has visibly entered the ball nut or if balls are out of the ball nut, replace the ball screw.</li> <li>• Cranking the ball screw through a significant part of its travel. If it jams, feel loose or has rough spots, replace the ball screw.</li> <li>• Dial indicator on a vertical flat of the ball screw indicates backlash between the ball screw and ball nut.</li> </ul>
Ball nut not tightened to the yoke	<ul style="list-style-type: none"> <li>• Inspection for space between the head of the bolt and the ball nut i.e. the retaining bolt has bottomed out in its thread and is not securing the ball nut to the yoke properly.</li> </ul>
Oil lines sheared	<ul style="list-style-type: none"> <li>• Visual inspection.</li> </ul>
Oil line blockage	<ul style="list-style-type: none"> <li>• Pump the oil and ensure that it flows evenly to the ways, ball screws and cross-slide.</li> </ul>
Z Ball screws not aligned properly	<ul style="list-style-type: none"> <li>• Manually turn the ball screw through the length of its travel. Pay particular attention to the movement near the headstock, the middle and the tailstock.</li> </ul>

**Note:** Ball screws are inspected throughout their entire travel for backlash and consistent torque. A ball screw should be good for millions of inches of travel if installed properly. Do not be too quick to replace a ball screw if there is insufficient indication that it is bad; this will just be a costly delay to resolving the real problem.

### 4.3 Pendant and Computer Module Diagnostics

The following table lists some problems and what these problems can lead to.

Possible problems	Can lead to
Poor cable connections	There are 2 cables connecting the rear of the Program Panel Assembly and the computer module. This is the Ethernet cable and I/O cable (ends with a DB25 connector). Make sure both cables are properly fastened on both the Program Panel Assembly and the Computer Module
Pendant locks up	<p>On the rear of the Program Panel Assembly, identify the "Key Press" D3 LED (second row of LED group located above the D-Sub connector to Overlay Assembly PCB). Press a numerical key and confirm the LED turns on when the key is pressed. Turns off when the key is no longer pressed. This confirms the keys are operating correctly.</p> <p>Press the E-stop button and see if lock up clears if not then do the following: Turn the Program Panel Assembly off (remove power from the computer module), wait at least 30 seconds, and connect power back to the computer module. Check to see if the malfunction has been remedied.</p>
Low voltage or power problem for the pendant.	<p>Can cause the system to lock up and the flash drive to act abnormally.</p> <p>Refer to the diagnostic LEDs on the rear of the Pendant. The three power LEDs (+5VDC, +12VDC and +24VDC) should be on.</p> <p>If not, ensure the cables on the rear of the pendant are securely connected to both the pendant and computer module. Ensure power is supplied to the computer module.</p>

Possible problems	Can lead to
LCD backlight burns out	If the LCD appears to be blank with no light showing, shine a light onto the LCD. If characters can be seen on the LCD, the LCD backlight is not functioning.
Faulty E-stop switch	Refer to the diagnostic LEDs on the rear of the Overlay Board on the back of Program Panel Assembly. Confirm E-Stop is not engaged. Verify ESTOP cable connections to Program Panel Assembly Overlay PCB board. Confirm D7 D8 are ON and D24 and/or D25 LEDs are not lit up. Replace the ESTOP switch. (When the E-Stop is not engaged (i.e. out), the N.C. contacts of the switch connect signals that turn on D7 with D24 LEDs and D8 with D25 LEDs. If the E-STOP is pushed-in and contacts open it causes D24 and D25 LEDs to go OFF.)  The switch can be stuck open or closed (pressed). If it is stuck closed the switch will need to be replaced because the user will have no way to get rid of the message. If it is open it will allow the machine to still operate but it will be unsafe for the user. The switch will still need to be replaced.
Overlay failure (keys on pendant)	Certain buttons on overlay do not work. Do code 81 to verify each key beeps.

#### 4.4 Motor Diagnostics

The Z-axis Motor assembly is comprised of 2 parts: The Motor Encoder and the Motor. The motors are brushless powered by 110 volt three phase power from servos operating on 208V input. The servo driver is also an integral part of servo system, which is discussed in the next section. X-axis motor assembly is comprised of 3 parts: The Motor Encoder, the Motor and the brake. The integral brake engages upon power shutdown or when the computer module turns off the brake power.

**WARNING!**  
**Do not work with the motors unless the power is disconnected from the machine.**

Rarely do both the X and Z motor/servo systems fail at the same time and in the same way. So, if your problem is occurring on both axes, its source is probably somewhere else.

##### 4.4.1 Cable Connections

Check the motor cable connections from the servo to motor. Verify there are no loose connections.

## 4.5 Servo Drivers

The servo drivers are used to control the motors. They are run on three phase 200-to-240-volt power. The three (3) servo drivers are located in the electrical cabinet. There are two power sources: one for the control circuit which powers the LED display and the main terminals used for the power output circuit. The control circuit is run by single phase connection that is active when the machine is powered on, while the power output three phase circuit is energized through K1 relay controlled by the computer module.

The computer module outputs a command to each servo drive via a signal with a voltage which is between - 10 and +10 volts. The + and – voltage dictates the motor rotation direction and the magnitude sets the speed of rotation.

Indications:

- Problems moving just one axis. The axis faults out on the screen.

Servo Types:

- Turret is a light duty driver with power of 200W
- X and Z are a heavy duty drivers with power of 1kW

When the AC servo drive has a fault, the LCD will display "ALnnn". :AL" indicates the alarm and "nnn" indicates the drive fault code. The following is a list of the fault codes:

**Servo Drive Fault Messages**

Fault Messages		
Display	Fault Name	Fault Description
AL001	Overcurrent	Main circuit current is higher than 1.5 multiple of motor's instantaneous maximum current value.
AL002	Overvoltage	Main circuit voltage has exceeded its maximum allowable value.
AL003	Undervoltage	Main circuit voltage is below its minimum specified value.
AL004	Motor error	The motor does not match the drive. They are not correctly matched for size (power rating).
AL005	Regeneration error	Regeneration control operation is in error.
AL006	Overload	Servo motor and drive is overload.
AL007	Overspeed	Motor's control speed exceeds the limit of normal speed.
AL008	Abnormal pulse control command	Input frequency of pulse command exceeds the limit of its allowable setting value.
AL009	Excessive deviation	Position control deviation value exceeds the limit of its allowable setting value.
AL010	Reserve	Reserve
AL011	Encoder error	Pulse signal is in error.
AL012	Adjustment error	Adjusted value exceeds the limit of its allowable setting value when perform electrical adjustment.
AL013	Emergency stop activated	Emergency stop switch is activated.
AL014	Reverse limit switch error	Reverse limit switch is activated.
AL015	Forward limit switch error	Forward limit switch is activated.

**Figure 4.5a Motor Servo Driver Fault Errors**



## 4.6 Electrical

### 4.6.1 Checking A/C Voltage

This procedure tests for the 208 VAC for the control. Check the power input to the computer module on fuses F10 and F11. Use a Voltmeter, reading A/C volts

- Acceptable range is 200V to 240V

**Note:** Systems running consistently close to the high or low values may have problems when normal voltage fluctuations push the voltage out of the acceptable range.

### 4.6.2 Checking Fuses

To locate the fuses and their sizes, refer to the Electrical Cabinet drawing 29103-27 found in Section 8.

To check fuses:

1. Use a Multimeter (Volt/Ohmmeter); select "OHM" or "W".
2. Remove the fuse completely from the pendant display or computer module.
3. Place a lead of the meter on each end of the fuse.
  - A good fuse reads 0 (zero) or close to it.
  - A bad fuse reads Open or Infinity or OL (over-limit).

### 4.6.3 Main Electrical Enclosure

The electrical enclosure is made up of the following main components:

1. AC drive – used to control the spindle motor.
2. Spindle Motor Breaking Resistors: 3 breaking resistors – used to limit BUS voltage of the AC Drive. To verify the resistors are good, measure the resistance across B1 and B2 of the AC drive. For the TC2RX, these connected resistors should measure 20 ohms (+/-2 ohms). TC2RX uses (3) 500 watt 60 ohm resistors.
3. X-axis drive breaking resistor. It utilizes a single 500W 30 Ohms resistor.
4. Computer Module – see section 4.6.4.
5. Servo drivers – servo drivers for the Turret, X and Z-axis motors.

### 4.6.4 Computer Module Connections

The list below describes what takes place through each connection. Power reaches the AC IN directly on the Computer Module. From there power is distributed through the system. This power is used to send power to the Program Panel Assembly through the I/O cable.

The following is the set of connections for the Computer Module:

- Spindle Encoder input – CPC14
- 2 USB ports – not for users
- Com ports – 1 and 2. COM1 for testing the computer module BIOS and COM2 is a spare.
- Ethernet connector – master and slave communicate via an Ethernet cable between Program Panel Assembly and computer module
- AC power input – 200 to 240 volt for USA
- Machine ID key – DB25
- Pendant I/O – DB25 – Carries E stop and run panel buttons back and forth from Program Panel Assembly to computer module
- Handwheel/Jog connector – DB25
- Motor and Spindle axis connectors – DB25 – spindle, X, Turret, and Z axis.
- 22 inputs, the following inputs are all 24VDC
  - P1-IN REMOTE ESTOP – used for jumper only
  - P10-IN SPARE – used for jumper only

- P60-IN DOOR SWITCH
  - P6-IN X-HOME – X axis home switch
  - P7-IN Z-HOME – Z axis home switch
  - P34-IN AIR PRESS – monitors the air pressure of the CNC Turret
  - P48-IN PEDAL – Hydraulic chuck pedal input
  - P29-IN HYD PRESS – monitors hydraulic pump pressure of hydraulic chuck option only
  - P32-IN LUBE LOW/PRESS – input for lube pump, signal low pressure or low oil in reservoir
  - P59-IN – monitors Hydraulic Chuck option inputs only
  - P67-IN – monitors Turret inputs; HOME, CLAMP, UNCLAMP; 1 spare
  - P74-IN-I/O AUX – used on AUX option only
  - P68-IN SPARE – extra inputs, 4 total
  - P38-I/O SPARE – extra input
  - P71-IN SPARE – extra input
  - P72-IN SPARE – extra input
  - P30-IN SPARE – extra input
  - P31-IN SPARE – extra input
  - P35-IN SPARE – extra input
  - P25-IN SPARE – extra input
  - P26-IN SPARE – extra input
  - P27-IN SPARE – extra input
  - P28-IN SPARE – extra input
- 2 outputs with N.O. contacts:
    - P54-OUT – HC IN, used to energize IN solenoid
    - P55-OUT – HC OUT, used to energize OUT solenoid
- 11 outputs, the following outputs are all 24VDC
    - P61-OUT DOOR UNLOCK door unlocking solenoid.
    - P39-OUT TL UNCLMP Turret unclamp solenoid.
    - P49-OUT LUBE PUMP to run lube pump. Software controls frequency and discharge time.
    - P50-OUT COOLANT PUMP – output to run coolant pump
    - P76-OUT 24VDC – output to run work lamp
    - P75-OUT 24VDC - Used as part Aux I/O and spare voltage output
    - P36-OUT SPARE
    - P40-OUT SPARE
    - P41-OUT SPARE
    - P51-OUT SPARE
    - P56-OUT SPARE

#### 4.6.5 Cable Connections

The lathe machines use several cables to communicate between systems. It is often the case that what appears to be the failure of an electrical component is actually attributable to a poor connection.

Indications:

- Control problems, chronic or intermittent.
- Motor problems.
- Measurement problems.

Explanation:

1. Turn off and unplug the system from the wall.

**WARNING!**

**Do not plug and unplug connectors with the system power on. This may cause damage to the connector board and harm to the technician.**

2. Visually inspect the connections for excessive debris, moisture, or obvious damage.
3. Carefully clean any chips away from the connectors.

4. One-by-one, take out each connector and then plug them back in. Do the same at the computer/display.
5. Make sure the screws are tightened on each of the connectors.

## 4.7 Door Switch

TC2RX TRAK lathes use a door interlock switch to verify to the control that the door is closed in various modes of operation. This switch has two circuits that are wired normally open but are forced closed when the door is closed. Computer module has two LEDs indicators near P60 – door switch input connector allowing for easy trouble shooting of the door switch circuits. The door switch is also equipped with door locking feature controlled by computer module. Door lock can also be engaged by pressing the “Door Lock” button on the run panel.

## 4.8 Service Codes

Service codes are broken down into the 5 following categories: software, machine setup, diagnostics, user options/defaults and lubrication pump control.

All Service Codes are accessed in the SET-UP Mode by pressing the soft key for “SERV CODES”. The service codes can be found under one of the headings listed on the main screen. Press the heading you want to access the code in question. If you know the code #, press the CODE # softkey and it will take you directly to the code in question. Press CODE #, enter the number you want, press SET

### 4.8.1 Software Codes

The following codes pertain to software functions in the control. To get to any of these codes go to Service Codes, press “A” and press the code you wish to view.

**Note:** *If you are working with the SWI Customer Service Group, write the values down for Code 33. These values will be valuable for troubleshooting.*

#### 4.8.1.1 Code 33: SoftwareID

The Code 33 is the software identification procedure. In code 33 we can see:

- **Master Version** - the version of the system you have installed on the master board.
- **Slave Version** - the version of software installed on slave board that is responsible for motion control and servo interfaces.
- **ID key** number identifying the machine.
- **Operating System Versions** – shows the versions of the Windows operating systems.

#### 4.8.1.2 Code 141: Load Configuration File to Computer

This code allows you to load your configuration file from a selected drive to your hard drive. The configuration file consists of items such as calibration and backlash constants, lube pump defaults. This code is used when a computer module or hard drive has been replaced.

#### 4.8.1.3 Code 142: Save Configuration File from the Computer

This code allows you to save your configuration file to an external thumb drive. The configuration file consists of items such as calibration and backlash constants. This code is used when a computer module or hard drive needs to be replaced. This stores the configuration file from the hard drive to an external thumb drive. It is a good idea to do this code after the machine is initially setup so these values can be saved and used in the future. If the computer or hard drive fails, then you will not have the ability to save the configuration file and the machine will need to be re-setup when the computer or hard drive is replaced.

#### 4.8.1.4 Code 316 : Update Software

Load upgrade disk in an external drive and press this service code. New software will automatically download and control will reboot.

#### **4.8.1.5 Code 318 : Activate Converters or Options**

See programming and operating manual.

### **4.8.2 Machine Set-Up Codes**

The following codes are used primarily when setting up a new machine. To get to any of these codes go to Service Codes, press "B" and press the code you wish to view.

#### **4.8.2.1 Code 128: Input Backlash Constant**

Code 128 allows you to enter the backlash values for each axis. It displays the value after it enters.

#### **4.8.2.2 Code 311: Run Machine with Spindle Off**

This service code toggles this function on or off. It defaults to off from the factory, which means the spindle must be on for a program to run. If it is on and you forget to turn the spindle on, the tool will move to Z rapid and wait for the spindle to come on. This function will be needed if you are running a repeatability program with an indicator in the spindle. Make sure this feature is on when cutting parts.

#### **WARNING!**

**Use only chucks which are rated to the maximum RPM of the lathe.**

#### **4.8.2.3 Code 400: Update Foreign Language MLS**

Used for foreign language installation. Please contact your distributor for further details.

#### **4.8.2.4 Code 505: Overtravel Soft Limits**

Used to set and turn ON/OFF the software limits of axes travel.

When entering this service code, both the soft limits will be disabled so as to allow for setup or troubleshooting. If a soft limit is triggered, it will stop the motor from moving any further, but will not fault out or kill power to the motor.

In addition to the DRO, the motor index angle for each axis relative to the limit switch can be seen.

SOFT LIMIT ON / OFF – You can choose to toggle the soft limits on or off. They will default to off when entering this service code, but will always turn back on after exiting.

#### **4.8.2.5 Code 510: Spindle RPM Calibration**

This service code calibrates the spindle using its encoder, simply follow the on-screen instructions. Please note that when installing new machine, or replacing computer module, that if no configuration is present, spindle may not run properly. Press LOAD DEFAULT to load spindle calibration defaults, if needed. This has no effect on other settings such as calibration, backlash, etc.

#### **4.8.2.6 Code 530: Serial Numbers and Mac Address**

Used to record machine and components serial numbers and display system MAC address

#### **4.8.2.7 Code 531 Hydraulic Chuck On/Off**

Used to enable/disable hydraulic chuck option. Should the installed hydraulic chuck option be disabled for any reason – please turn off the hydraulic pump Q13 breaker installed inside the electrical cabinet to disable the hydraulic fluid three phase pump along with code 531 set to OFF. Once the option is turned ON again, make sure the pump runs again with Q13 ON and check the system pressure. The pump clockwise rotation is controlled by input power phase sequence. Verify the pump operation every time this option is enabled from a non-operation state.

#### **4.8.2.8 Code 535: 8 Tool Turret Backlash and Home Offset**

Used to adjust turret backlash and home offset. Adjustment can be manual or automatic. If tools are heavy and unbalanced they can be set manually.

#### **4.8.3 Diagnostic Codes**

The following codes are used primarily when diagnosing a problem with the machine. To get to any of these codes go to Service Codes, press "C" and press the code you wish to view.

##### **4.8.3.1 Code 1: Program, Configuration File, Log Back up**

This service code captures all important data from the RX machine. This includes the users program, master and slave configuration files, master and slave message logs, master and slave fault logs etc. This is meant to be used to help solve problems that may pertain to the software. This file can then be emailed to the SWI service department. The files are saved to a Zip file.

##### **4.8.3.2 Code 54: Program Continuous Run**

This Code runs a program continuously without stopping for tool change commands. It is helpful in running a long period to identify an intermittent problem.

1. Prepare a program as you normally would.
2. Press **MODE, SET UP, "C", Code 54, INC SET**. The program run will start automatically.
3. Press **STOP** to stop, and **GO** to continue.

##### **4.8.3.3 Code 81: Keyboard Test**

This code is used to check if the keyboard is functioning correctly. It allows you to test each key on the pendant individually. When you press the keys, the corresponding box for that key will highlight on the screen. The pendant will also beep, indicating that the key is working correctly. If one of the keys does not work the program panel assembly or run panel may need to be replaced. If none of the keys are working chances are that the computer module will need to be replaced.

##### **4.8.3.4 Code 131: Manual DRO**

A manual diagnostic routine to check the X and Z motor encoders. Since X axis motor uses brake – the axis movement is restricted with X-axis servo not enabled. To check the Z axis motor encoder push E-STOP and turn the ball screw manually to display the encoder readings. This code will display the raw encoder counts before the calibration and backlash constants have been factored into the counts.

##### **4.8.3.5 Code 132 - Electronic Hand Wheel Test**

Turn the electronic hand wheel. The display should show count as the hand wheel is being turned. There should be no skipping and it should count smoothly while the hand wheel is being turned. One revolution of hand wheel should count from 0 to 99

##### **4.8.3.6 Code 314: Toggle Test Lights 'On' in Status Line**

This code toggles on and off 2 test lights that appear in status line, on the lower right side of the screen. The top light signifies if the master software is working. If functioning it should flash a green light. The bottom light signifies if the slave firmware is functioning. It will appear orange in run mode when it is processing information. Pressing the mode key will change this orange box to black. The orange box will also change to black when the program you are running reaches the 3rd event from the end of the program. If the firmware is locked up no keys will work. This code is useful for diagnosing intermittent problems with the control locking up

#### **4.8.3.7 Code 319: Message Log**

This code when turned on captures the commands that were sent to the servo system. It includes items such as positioning commands, errors, stop and go commands, etc. It may be helpful for identifying problems between programmed commands and executed commands. To turn on or off the error log press the softkey on the screen. The page forward and backward keys allow you to scroll through the file one page at a time. The data bottom key takes you to the bottom of the file and then changes to data top which will take you back to the top. Options allow for data logging selection. Real time messages are excluded by default.

#### **4.8.3.8 Code 320: Fault Log**

Used to view machine faults and to save data to a USB.

#### **4.8.3.9 Code 326: Look Up Message**

Allows user to display safety flashing messages, master messages and slave error messages on screen. Often used by translators converting English language to some other language.

#### **4.8.3.10 Code 327: Check Memory and Compact Flash**

Displays memory availability of various devices.

### **4.8.4 Operator Defaults/Options Codes**

The following codes allow the user to set programming defaults or turn features on or off. To get to any of these codes go to Service Codes, press "D" and press the code you wish to view.

#### **4.8.4.1 Code 79: Beeper On/Off**

This turns on the beeper to the control keys.

#### **4.8.4.2 Code 328: EPA On/Off**

Turn the EPA feature on or off

#### **4.8.4.3 Code 329: Hydraulic Chuck Clamping OD/ID**

This setting allows the machine to recognize how to clamp the material piece.

#### **4.8.4.4 Code 600: Manage User Profiles**

Use this service code to create, delete or reset user profiles.

#### **4.8.4.5 Code 602: MTConnect**

This service code is used for remote monitoring of the machine operation.

#### **4.8.4.6 Lube Pump Codes**

The following codes are used for programming and operating the lube pump. To get to any of these codes go to Service Codes, press "E" and press the code you wish to view.

#### **4.8.4.7 Code 300: Lube Pump Switch**

This code acts as a switch to turn the lube pump on for the programmed time set in Code 302.

#### **4.8.4.8 Code 301: Set Lube Pump cycle time**

This code sets the interval time between lube cycles. Set to 30 minutes by default.

#### **4.8.4.9 Code 302: Set Lube Pump discharge time**

This code sets the lube pumps discharge time. Set to 4 seconds by default.



# 5.0 Procedures for Replacements & Maintenance

## 5.1 Replacements

### 5.1.1 Brushless Motor Replacement

**WARNING!**  
**Do not work with the brushless motors unless the power is disconnected from the machine. The motors are run by 110 VAC. The servo drives are run on 208VAC. There is possibility of death by electrocution!**

1. Turn off power to the machine.
2. Each X (1KW) is mounted by the use of (4) M8-25 cap screws. The Z axis motor (1KW) is mounted by the use of (4) M8-25 screws. Be careful not to over-tighten these bolts and strip the threads. To set index angles see service code 505 and X & Z Home Switch Adjustments.

### 5.1.2 Servo Drive Replacement

**WARNING!**  
**Do not remove the Servo Drives unless the power is disconnected from the machine. The servo drives are run by 208 VAC. There is possibility of death by electrocution!**

The Servo Drive for each axis is mounted in the electrical cabinet using (3) M5-12 cap screws.

**DANGER!**  
**Always engage (push in) the Emergency Stop switch, turn the ProtoTRAK RX Control off, and disconnect the servo motor/driver cable and power wires.**

1. Press in the Emergency Stop.
2. Remove power from the machine.
3. Disconnect the two digital cables with DB connectors (CN1 and CN2).
4. Disconnect the incoming motor power 5 individual wires with lug termination from the drive (labelled L1-6, L2-6, L1-7, L2-7, L3-7) and motor cable (U, V, W, GND) Do not pull on the wires.
5. Remove the green ground wire by removing the green screw on the bottom left corner of the unit.
6. Mount the new servo drive in the cabinet. The servo drive is programmed for either X or Z axis.
7. Reconnect the green ground wire followed by the two digital cables and 8 power wires.



P/N	Description
28164-10	X Motor-Brushless-Delta-1KW W/ Brake
28164-1	Z Motor-Brushless-Delta-1KW
29980-TC2-X	SERVO DRIVE-DELTA-PROGRAMMED 1KW
29980-TC2-Z	SERVO DRIVE-DELTA-PROGRAMMED 1KW

**Figure 5.1.2 - Servo Drive and Motor Replacement & Part List**

### 5.1.3 Program Panel Assy and Computer Module Replacement

#### 5.1.3.1 Program Panel Assembly Replacement

1. Turn power off to the machine and control and remove back cover from the Pendant.
2. Unplug the run panel ribbon cables on the back side of the program panel assembly; unplug network cables and D-Sub to computer module connector.
3. Remove the program panel assembly from the pendant by removing the (8) M6 nuts that secure it in place.
4. Mount the replacement program panel assembly into Pendant with the (8) M6 mounting nuts.
5. Reconnect all the previously removed cable connections.

#### 5.1.3.2 Computer Module Replacement

1. Turn power off to the machine and control.
2. Unplug all the connectors connected to the Computer Module.
3. Remove the Computer Module from the Electric Box by removing the (6) M5-0.8x12 SHCS that secure it in place.
4. Replace the Computer Module and reinstall by mounting with the screws used to mount the previous unit.
5. Reconnect all the previously removed cable connections.

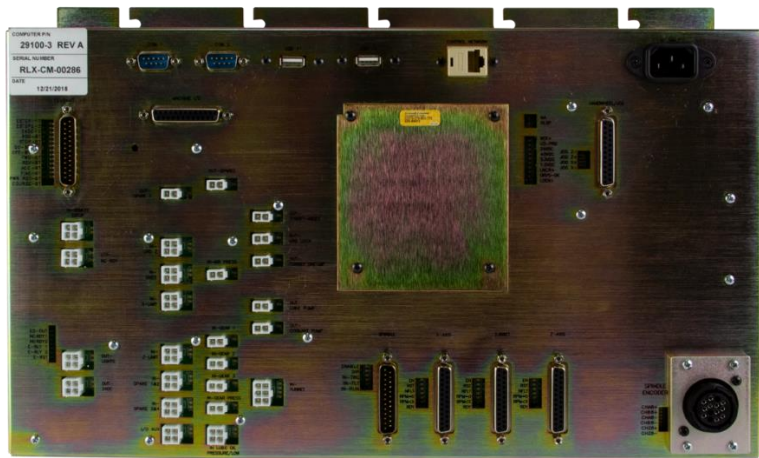

**Figure 5.1.3.2 – Program Panel & Computer Module Replacement**

Item	P/N	Description
1	31601-1	RLX PROGRAM PANEL ASSEMBLY
2	31602-4	RLX RUN PANEL ASSEMBLY
3	29100-10	RLX COMPUTER MODULE

**Figure 5.1.3.2 – Program and Run Panels, Computer Module Replacement**

#### 5.1.4 Updating the Program Panel and Computer Module Software

1. On the pendant, touch the "Status" soft key on the upper left portion of the touch screen. This will display the pendant and CM software version.
2. To verify the current software versions, go to <https://www.southwesternindustries.com/software>
  - Click on the "Current ProtoTRAK CNCs Software" tag. Find the RX section and refer to the software versions list.
3. To update to a more current version, first download the software from the website onto a USB Flash Drive.
4. Plug the USB Flash Drive into one of the pendant USB ports.
5. On the Program Panel, select the soft key "Service Codes". Type in "316" and press the ABS Set key. Follow the instructions on the screen.

**Note:** *Your configuration/calibration settings will not be changed by this procedure.*

If you wish to store your settings on a USB Flash drive, install a drive in one of the ports and use Service Code 142 to save the values. Service Code 141 can be used to restore the values on your Flash Drive back onto the pendant.

#### 5.1.5 Cable Routing on Machine & In Electrical Cabinet

Whenever you replace a cable or reroute a cable it is very important to keep the power cables and logic cables separated from each other. The power cables consist of the (3) 208-volt motor cables and (3) 208-volt power cables for the Computer Module and a coolant pump or lube pump cable. The logic cables are used to carry encoder signals between the servos and computer module. Mixing of the power and logic cables may cause noise from the power cables to interrupt the signals in the logic cables. This can lead to intermittent axis faults or repeatability problems.

### 5.1.6 Electronic Handwheel and ESTOP switch replacement

Electronic handwheel (PN 26538) is a part of run panel assembly. It is accessible from the back of the pendant assembly, after back cover removal. ESTOP switch (PN 21833-1) is also mounted in the run panel.

### 5.1.7 Spindle Drive Belt Replacement

The spindle drive motor is located inside the base pedestal, underneath the headstock. Access is gained by removing the left side bottom cover, and also removing the small motor access panel on the left-front of pedestal. When removing the belt, loosen (6) subplate mounting screws and loosen the belt tension screw until the belt has sufficient slack to be removed from the pulleys.

When installing the belt, loosen (6) subplate mounting screws and raise the motor using the belt tension screw. Initially, tension the belt to 48+/- 2 Hz using Bando tension meter VA-010.

Belt tension should be checked frequently during the first days of operation, and periodically thereafter. Keep the pulleys and belt clean and free of any foreign material to ensure long life and maximum traction.

In absence of Bando tension meter, a "Pencil Tester" similar to BUI4003 can be used. Tension the belt to approximately 5-6 lbs. at 3/8" deflection in the middle of the belt span.

### 5.1.8 Spindle Encoder Replacement

1. Unplug or remove all power from the lathe.
2. Remove the rear access cover to gain access to the encoder.
3. Loosen setscrews on flexible coupling and the bolts that hold the encoder on.
4. Slide the encoder off.
5. The spindle encoder assembly is only available as a complete unit. Do not disassemble.



### 5.1.9 Spindle Motor Replacement

Because of the weight and size of the spindle motor, and the restricted working space, special tools are required (motor removal rods) to replace the motor. Extreme caution must be used in sliding the motor from its mounting plate. Please refer to the service department for assistance.

### 5.1.11 Spindle Motor Wiring

The TRAK Lathe spindle motors are wired for 208 volts (low voltage configuration). The wiring consists of 3-phase power for the motor and 208 volt power for the spindle motor fan. Please see the motor junction box diagram for wiring information.

Each junction box contains 6 terminals. Make sure to hook up the wires to the same terminals after the replacement motor is installed. Failure to do so may cause the motor to run in the wrong direction.

The spindle motor fan wires are also found in the junction box. There is 1 hot wire, 1 neutral wire and 1 ground wire. It does not matter which wires are connected to the hot and neutral wires. All grounds from each cable are connected to either of the screws in the junction box.

Machines equipped with 480V transformer option have motors wired for High Voltage configuration at their junction boxes and run at 400V output from the AC Drive. Check your machine configuration when you replace the spindle motor.

## **5.2 Maintenance**

### **5.2.2 Calibration & Backlash Constants**

Calibration is used to teach the machine a known distance. Calibration is done at the factory using laser and does not need to be adjusted. Backlash constants were set as part of the installation and set-up of your system. They should be re-set when indicated in the Troubleshooting section or after the replacement of the computer module, or any parts of the drive train.

#### **5.2.2.2 Backlash Compensation**

**CODE 128:** Input Backlash Constant

Code 128 allows you to enter the backlash values for each axis. It displays the value after it enters.

Be sure not to enter too much backlash on any given axis. Too much backlash in the system may cause bi-directional repeatability problems or axis motor searching.

### **5.2.4 X & Z Home Switch Adjustments**

#### **5.2.4.1 X-Axis Home Switch Installation & Adjustment**

The home switch for the X-axis is mounted to the side of the carriage. The mounting bracket is slotted for adjustment. Also the corresponding dog is slotted. The home switch is set to a specific distance from the end of travel and is adjusted at the factory. The home switches that come on the TC2 should not need to be adjusted unless a component that is part of the drive train is changed, such as an axis motor or ballscrew. If the component is removed or replaced, we need to adjust the switch distance from the end of travel. The adjustment is 1½ of ball screw rotation from an end stop prior to the index angle fine tuning. The index pulse on the motor encoder should be approximately 180 degrees (+/- 45 degrees) from the home switch cam, this will ensure the homing algorithm works very reliability. Service code 505 is used to check the angle of the motor encoder versus the home switch cam. Due to the difficulty of the adjustment, we recommend calling TRAK for service.

#### **5.2.4.2 Z-Axis Home Switch Adjustment**

The home switch for the Z-axis is mounted on the back of the machine casting. It is not adjustable. The corresponding dog is attached to the side of the carriage and it is slotted for adjustment. The home switch is set to a specific distance from the end of travel and is adjusted at the factory. The home switches that come on the TC2 should not need to be adjusted unless a component that is part of the drive train is changed, such as an axis motor or ballscrew. If the component is removed or replaced, we need to adjust the switch distance from the end of travel. The adjustment is 1½ of ball screw rotation from an end stop prior to the index angle fine tuning. The index pulse on the motor encoder should be approximately 180 degrees (+/- 45 degrees) from the home switch cam, this will ensure the homing algorithm works very reliability. Service code 505 is used to check the

angle of the motor encoder versus the home switch cam. Due to the difficulty of the adjustment, we recommend calling TRAK for service.

# 6.0 Turret

## 6.1 Troubleshooting the Turret

The following fault messages will appear on the screen when there is a problem with the turret:

- **Fault 85 – Impossible Tool Position**

This message will appear if the turret goes to a tool number that you did not select. For example, the operator chose Tool 2 and the turret went to Tool Station 6. To fix this problem, re-initialize the system by choosing Service Code 147. Contact Southwestern Industries Customer Service.

- **Fault 86 – Turret Power Problem**

This message will appear if the power is interrupted to the turret. It could indicate that no power or low power is getting to the turret. Check that the Computer Module and AC Drive/Motor (for the 8 Tool Turret) is receiving power.

- **Fault 87 – Turret Air Pressure Problem**

This message will appear if the air pressure sensor senses low air or no air pressure. The recommended air pressure for the turret is 90 psi. The air pressure should be 90 psi and no more than 100 psi for the turret to work correctly. **Do not exceed 100 psi. This will void the warranty on the turret.**

- **Fault 88 – Turret Not Initialized**

This message will appear if the turret does not know its present position. An example of this would be if the turret stops in the middle of a tool change. An interruption of power or air may cause this fault. Pressing the E-stop button can also cause this problem if the tool is not in a known position. In order to initialize the turret, go to SETUP, TOOL GROUP, 4 or 8 TOOL, followed by HOME turret.

**Note:** *The air flow control fitting for the Turret clamp also plays a part in how long it takes for the turret to finish the initialization routine. Thus, the air flow control clamp should be set to 2.5 turns from full open.*

- **Fault 89 – Turret Time Out**

This message appears if the turret does not get to position after a few seconds. This may be caused by an internal problem inside the turret such as a broken gear or jammed component. Very low air pressure may also cause this fault. It should take no longer than 2 or 3 seconds for the turret to move between positions.

### 6.1.5 Warranty Issues

The SWI turret is under warranty for 1 year. If it is determined that there is a problem with the turret it will need to be returned for repair. Control problems are warranted by Southwestern Industries, Inc. for 1 year.



## 7.0 Introduction to Self-Service

The objective of this section of the manual is to allow the user of the ProtoTRAK Control to resolve the majority of potential service problems.

This manual assumes that the user is not experienced with CNC troubleshooting and repairs. Special tools are not required for the procedures described in the manual.

Please see Sections 3 for basic troubleshooting sections of the manual.

### 7.1 When You Have a Service Problem

SWI recommends that you consult this manual or our web site first. We also have a Dozuki site with detailed troubleshooting procedures <https://trakmtsupport.dozuki.com/>. Often it will be possible for you to resolve the problem yourself or isolate the problem to a particular cause.

Your next step is to contact the SWI Customer Service Group for assistance.

#### 7.1.1 Communication with the SWI Customer Service Group

SWI Service Department Direct Line: (800) 367-3165

Web Address – [www.trakmt.com](http://www.trakmt.com)

This phone line rings directly into the SWI Customer Service Group. If a Customer Service Representative (CSR) is not available within the first few minutes, your call is transferred into our voice mail system.

Our voice mail is continuously monitored. If you have an emergency, indicate this in your message. Our Service Voice Mail box number is 555.

SWI Service Department Direct Fax number (310) 886-8029

Customer Service Group hours:

Monday - Friday 7:00 AM to 4:30 PM Pacific Time.

SWI observes a normal holiday schedule.

### 7.2 Replacements

#### 7.2.1 Exchange Program

SWI keeps in stock the major subassemblies required to resolve service problems. With very few exceptions, the part needed to resolve any given service problem is on the shelf and ready to ship. A little bit of troubleshooting on your part means that we can get the right part to you fast.

After replacing the failed unit with the replacement unit, simply put the failed unit in the same box that the replacement part came in and ship it back to us via UPS ground service.

This unique Exchange program gives our customers access to refurbished "like-new" subassemblies that have been brought up to current design revisions and go through the same QC procedures as our new products. These high-quality replacement units are available at a fraction of the price of a new subassembly.

#### 7.2.2 Return Material Authorization (RMA) Number

All shipments of replacement parts are accomplished through our Return Material Authorization (RMA) system. At the same time the CSR is diagnosing the problem and ordering the part, they will issue an RMA number that will allow us to efficiently process the return part.

# TRAK Warranty Policy

## Warranty

TRAK products are warranted to the original purchaser to be free from defects in workmanship and materials for the following periods:

Product	Warranty Period	
	Materials	Factory Labor
New TRAK/ProtoTRAK	1 Year	1 Year
Any EXCHANGE Unit	90 Days	90 Days

The warranty period starts on the date of the invoice to the original purchaser from Southwestern Industries, Inc. (SWI) or their authorized distributor.

If a product, subsystem or component proves to be defective in workmanship and fails within the warranty period, it will be repaired or exchanged at our option for a properly functioning unit in similar or better condition. Such repairs or exchanges will be made FOB Factory/Los Angeles or the location of our nearest factory representative or authorized distributor.

## Warranty Disclaimers

- This warranty is expressly in lieu of any other warranties, express or implied, including any implied warranty of merchantability or fitness for a particular purpose, and of any other obligations or liability on the part of SWI (or any producing entity, if different).
- Warranty repairs/exchanges do not cover incidental costs such as installation, labor, freight, etc.
- SWI is not responsible for consequential damages from use or misuse of any of its products.
- TRAK products are precision mechanical/electromechanical/electronic systems and must be given the reasonable care that these types of products require. Evidence that the product does not receive adequate Preventative Maintenance may invalidate the warranty. Excessive chips built up around ballscrews and way surfaces is an example of this evidence.
- Accidental damage, beyond the control of SWI, is not covered by the warranty. Thus, the warranty does not apply if a product has been abused, dropped, hit or disassembled.
- Improper installation by or at the direction of the customer in such a way that the product consequently fails, is considered to be beyond the control of the manufacturer and outside the scope of the warranty.
- Warranty does not cover wear items that are consumed under normal use of the product. These items include, but are not limited to: windows, bellows, wipers, filters, drawbars and belts.

F10302 | Rev: 020620